

## CONTENTS

- I. 01 Base part
- II. 02 Column part
- III. 03 Table part
- IV. 04 Feed part
- V. 06 Headstock part
- VI. 09 10 Cooling & Lubricating part
- VII. F Accessories part

# 01 Base Part

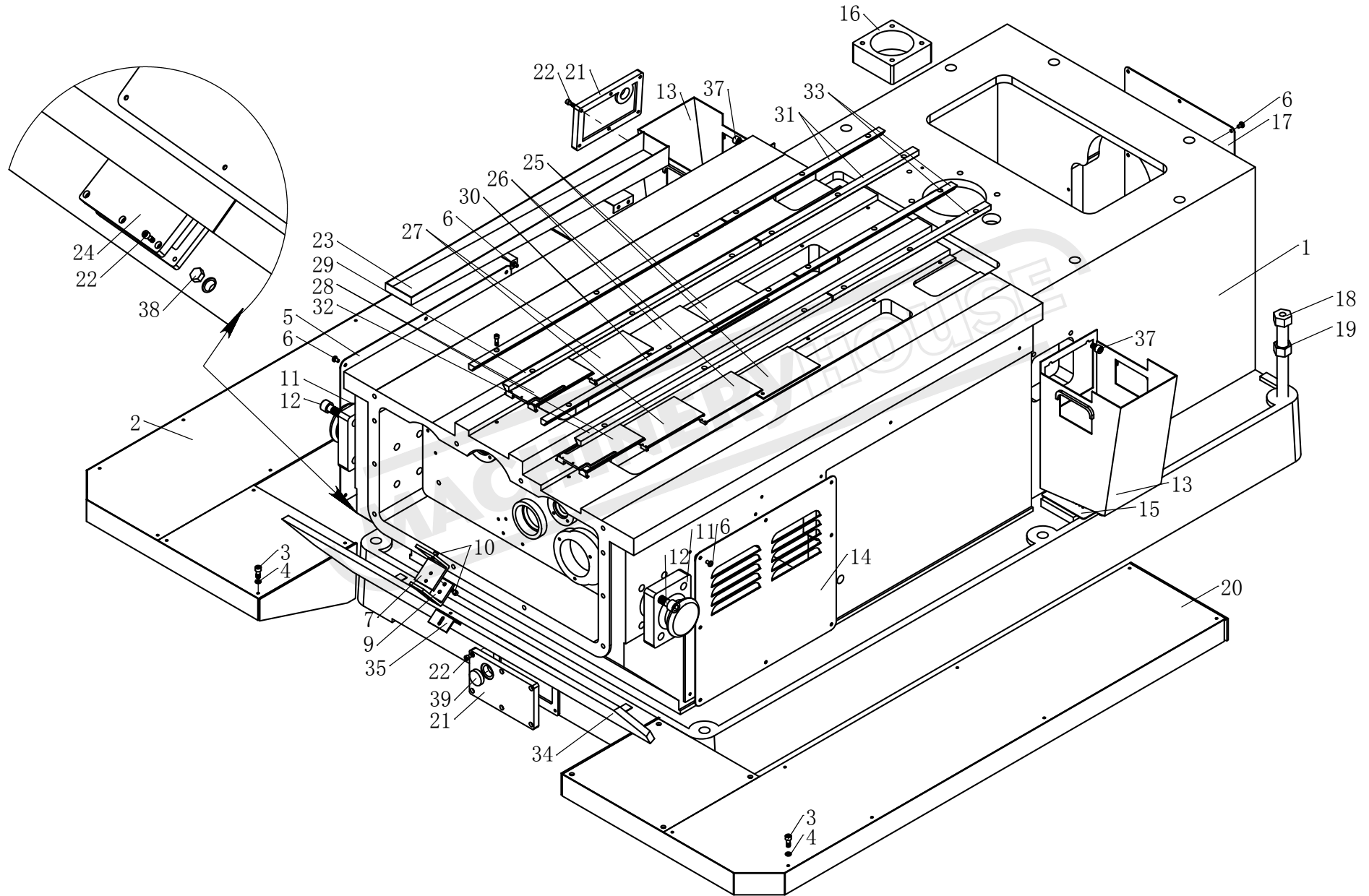

## 01 Base Part

No.	Name	Qty
1	Base	1
2	Plate	1
3	M8x20 Hexagon socket head cap screw	2
4	8 Elastic washer	2
5	Cover	1
6	6x10 Cross recessed pan head screw	4
7	Plate	1
8	M6x12 Hexagon socket head cap screw	1
9	Plate	1
10	M6x20 Hexagon socket head cap screw	9
11	Lifting bracket	2
12	M16x35 Hexagon socket head cap screw	2
13	Filter box	2
14	Cover	1
15	Filter	2
16	Bracket	1
17	Cover	1
18	Adjusting screw	1
19	M24 Nut	1
20	Plate	1
21	Cover	2
22	M6x16 Hexagon socket head cap screw	3
23	Coolant drain	1
24	Cover	1
25	Wiper	2
26	Wiper	2
27	Wiper	2
28	Wiper	2
29	Scale	1

# 01 Base Part

No.	Name	Qty
30	Scale	2
31	Scale	2
32	Scale	1
33	Scale	2
34	Plate	1
35	Plate	1
36	Cover	1
37	M10x16 Hexagon socket head cap screw	2
38	M18x1.5 Oil plug	2
39	M27x1.5 Oil scale	2

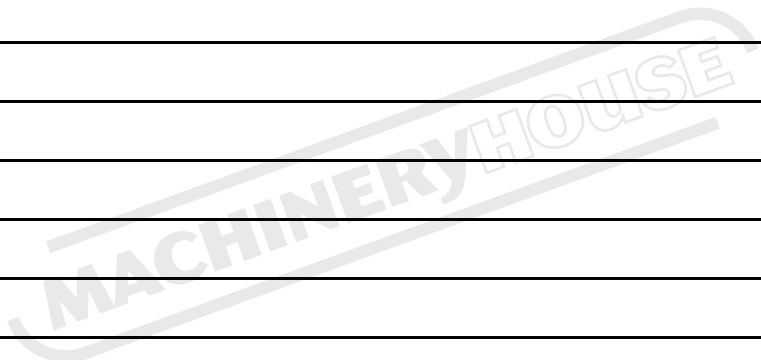

# 02 Column part

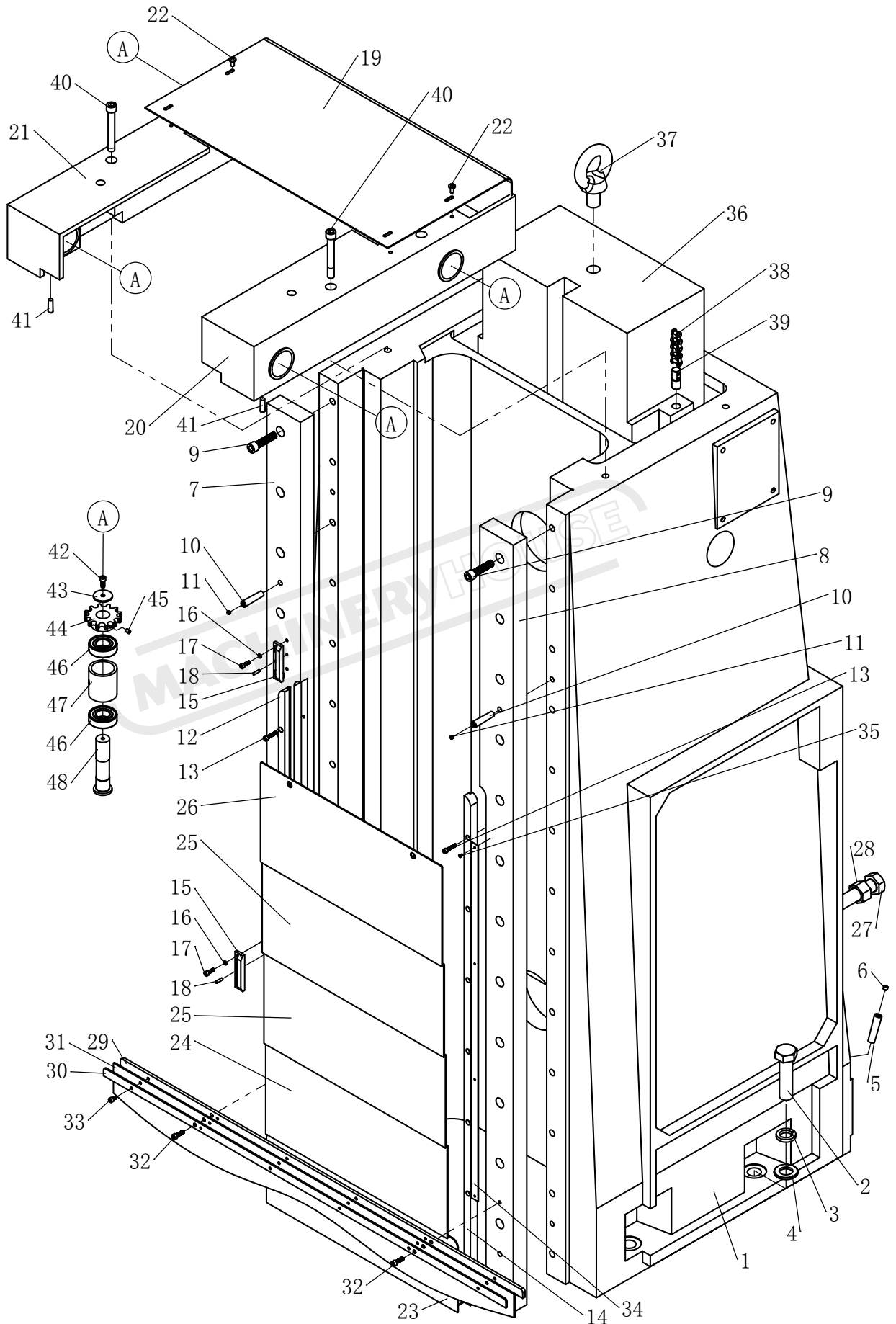

## 02 Column part

No.	Name	Qty
1	Column	1
2	M24x90 Hexagon bolt	6
3	24 Helical spring lockwasher	6
4	24 Plain washer	6
5	A12x55 Taper pin	2
6	M8x8 Set screw	2
7	Right pressure plate	1
8	Left pressure plate	1
9	M12x50 Hexagon socket head cap screw	26
10	A10x50 Taper pin	4
11	M6x6 Set screw	4
12	Right slipper path	1
13	M5x25 Hexagon socket head cap screw	14
14	Left slipper path	1
15	Fixed stop dog	2
16	5 Helical spring lockwasher	4
17	M5x16 Hexagon socket head cap screw	4
18	4x16 Taper pin	2
19	Cover	1
20	Bracket	1
21	Right bracket	1
22	M6x12 Cross recessed pan head screw	4
23	Wiper	1
24	Wiper	1
25	Wiper	2
26	Wiper	1
27	M24x240 Hexagon bolt	1
28	M24 Hexagon nut	1
29	Supporting bar	1

## 02 Column part

No.	Name	Qty
30	Pressure bar	1
31	Rubber guard	1
32	M6×20 Hexagon socket head cap screw	2
33	M5×10 Hexagon socket head cap screw	6
34	Scale	1
35	M3×6 screw	4
36	Balance block	1
37	M24 Lifting eye bolt	1
38	10A-1×90 Roller chain	2
39	Screw	2
40	M12×90 Hexagon socket head cap screw	4
41	A8×28 Taper pin	4
42	M6×16 Hexagon socket head cap screw	4
43	Washer	4
44	Chain wheel	4
45	M6×10 Set screw	4
46	6205-2Z 25×52×15 Bearing	8
47	Bush	4
48	Shaft	4

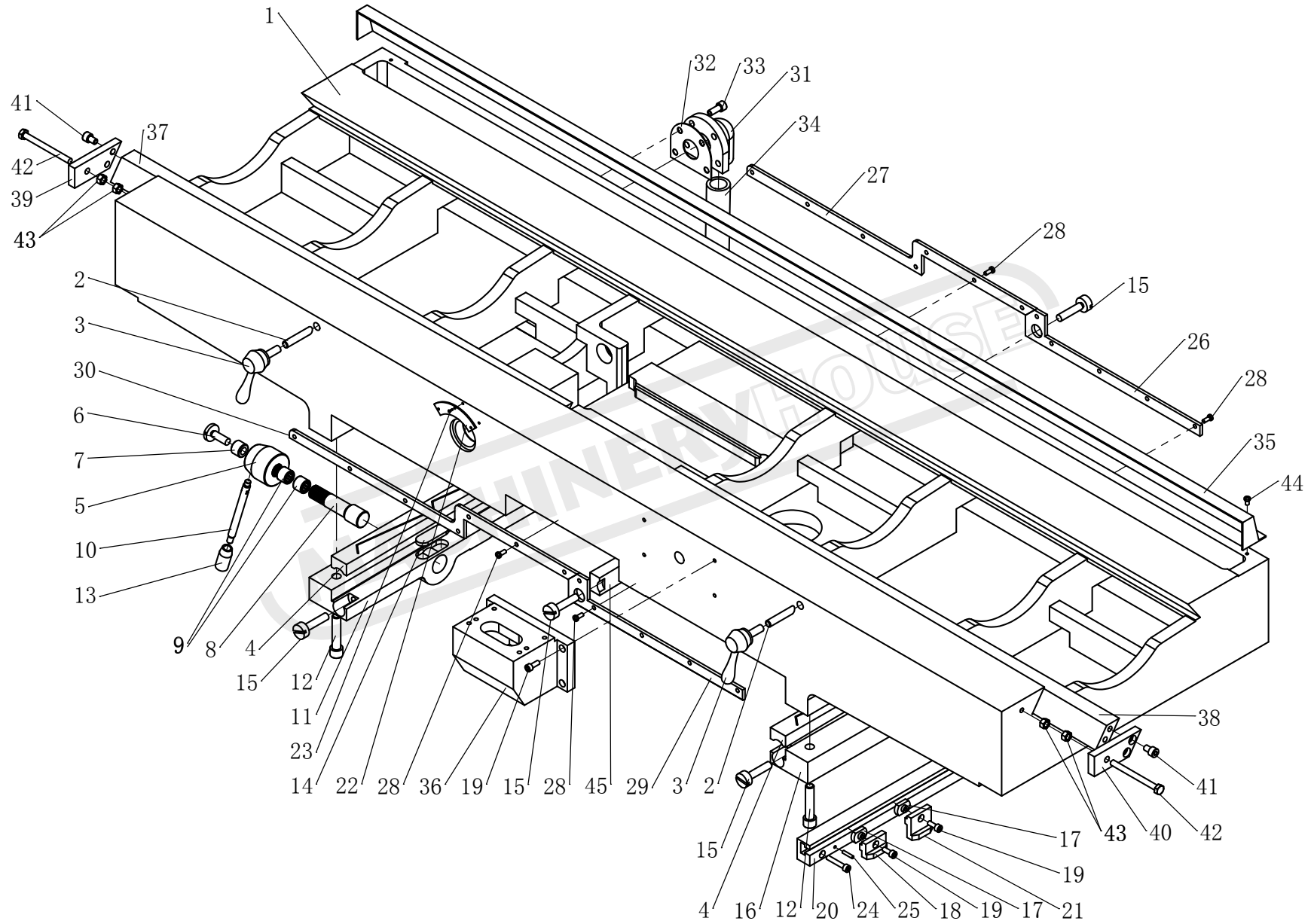

# 03 Table Part



# 03 Table Part

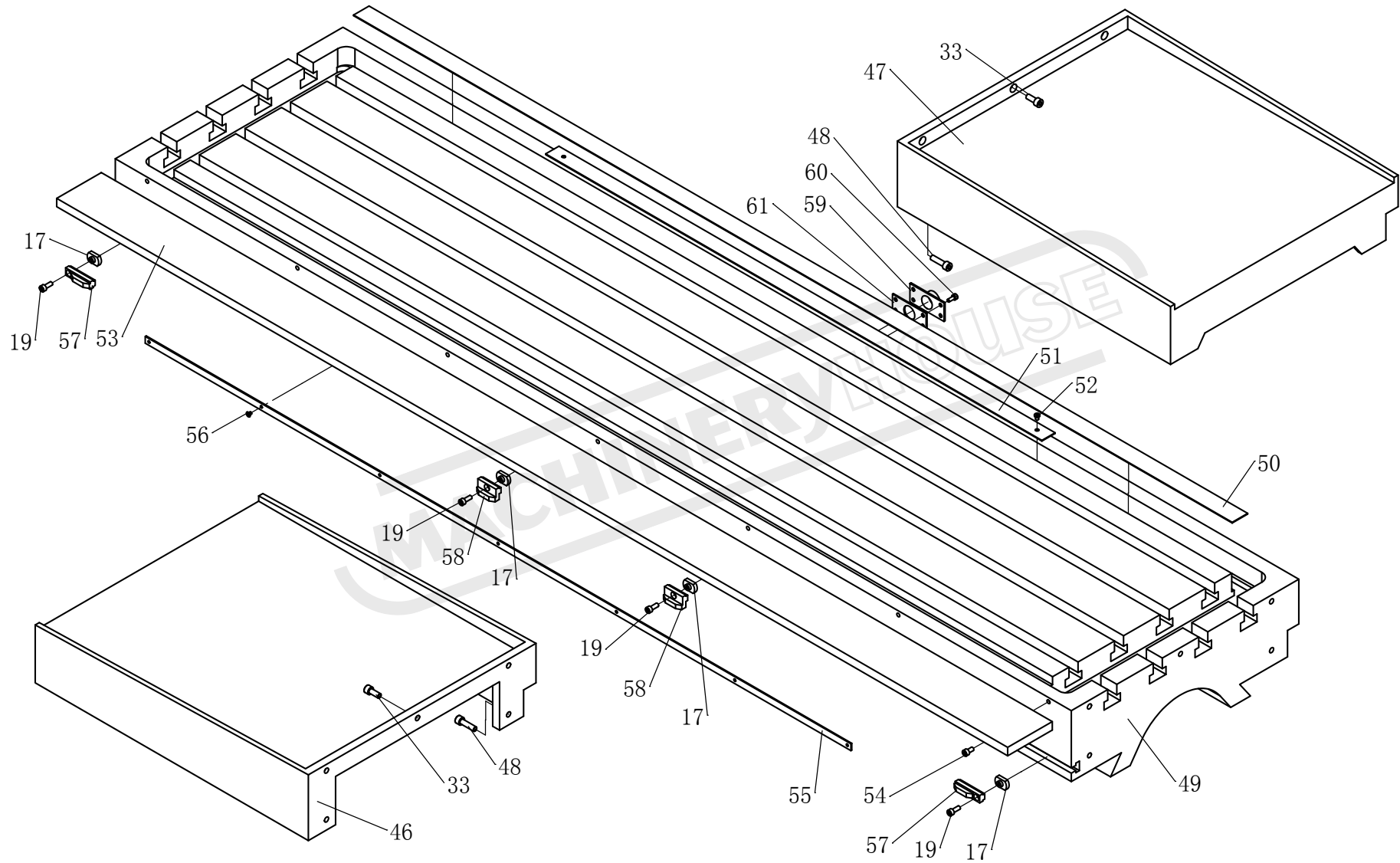

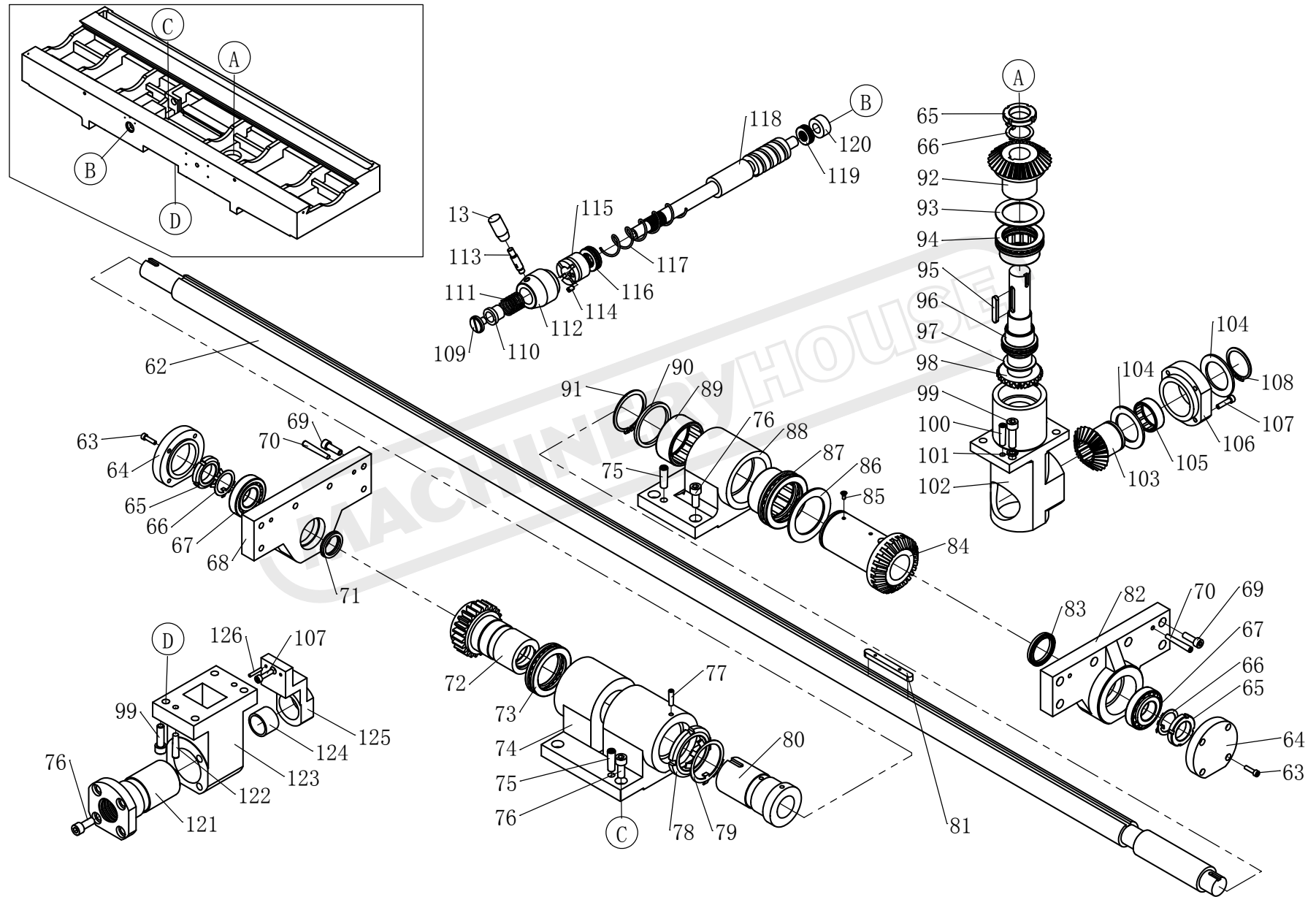

03 Table Part

## 03 Table part

No.	Name	Qty
1	Saddle	1
2	Rod	2
3	B-M12x95x40 Handle	2
4	Gib	2
5	Handle boss	1
6	Screw	1
7	Collar	1
8	Shaft	1
9	NK20/20 20x28x20 Bearing	2
10	Handle lever	1
11	Pressure plate	1
12	M12x55 Hexagon socket head cap screw	10
13	B-M8x40 Grip	2
14	Key	1
15	Screw	6
16	Pressure plate	1
17	Nut	8
18	Dog	2
19	M6x16 Hexagon socket head cap screw	12
20	Bracket	1
21	Dog	2
22	Name plate	1
23	2x6 Rivet	3
24	M6x35 Hexagon socket head cap screw	4
25	4x20 Taper pin	2
26	Wiper	1
27	Wiper	1
28	M5x12 Cross recessed pan head screw	26
29	Wiper	1

## 03 Table part

No.	Name	Qty
30	Wiper	1
31	Elbow	1
32	Washer	1
33	M8x20 Hexagon socket head cap screw	1
34	Pipe	10
35	Wiper	1
36	Bracket	1
37	Gib	1
38	Gib	1
39	Plate	1
40	Plate	1
41	M8x12 Hexagon socket head cap screw	4
42	M8x90 Hexagon bolt	2
43	M8 Hexagon nut	4
44	M5x8 Cross recessed pan head screw	5
45	Gib	1
46	Cover	1
47	Cover	1
48	M8x30 Hexagon socket head cap screw	4
49	Table	1
50	Cover	1
51	Filter	1
52	M5x6 Cross recessed pan head screw	2
53	Guard	1
54	M6x12 Hexagon socket head cap screw	7
55	Scale	1
56	M4x6 Cross recessed pan head screw	7
57	Dog	2
58	Dog	2

## 03 Table part

No.	Name	Qty
59	Pipe joint	1
60	M5x12 Hexagon socket head cap screw	4
61	Washer	1
62	Lead screw	1
63	M5x20 Hexagon socket head cap screw	8
64	Cover	2
65	M30x1.5 Nut	3
66	30 Check washer	3
67	30206 Tapered roller bearing	2
68	Bracket	1
69	M8x25 Hexagon socket head cap screw	12
70	6x50 Taper pin	4
71	FB030050 Oil seal	1
72	m=3.15 z=24 Worm gear	1
73	51111 Thrust ball bearing	1
74	Bracket	1
75	10x35 Taper pin	4
76	M10x25 Hexagon socket head cap screw	12
77	6x26 Taper pin	1
78	M55x2 Lock nut	1
79	55 Check washer	1
80	Bush	1
81	Key	1
82	Bracket	1
83	FB040060 Oil seal	1
84	m=2.75 z=32 Bevel gear	1
85	M4x10 Screw	2
86	Washer	1
87	NKX60 Combination gear	1

## 03 Table part

No.	Name	Qty
88	Bracket	1
89	NK60/25 60x72x25 Bearing	2
90	Washer	1
91	60 Circlip for shaft	1
92	m=2.75 z=32 Bevel gear	1
93	Washer	1
94	NKX50 Combination gear	1
95	8x45 Flat key	1
96	NKX35 Combination gear	1
97	Washer	1
98	m=2.75 z=24 Bevel gear	1
99	M10x35 Hexagon socket head cap screw	8
100	8x35 Taper pin	2
101	10 Spring washer	4
102	Bracket	1
103	m=2.75 z=24 Bevel gear	1
104	Washer	2
105	NK45/30 45x55x30 Bearing	1
106	Cover	1
107	M6x25 Hexagon socket head cap screw	4
108	45 Circlip for shaft	1
109	Screw	1
110	Bush	1
111	2x23x30 Spring	1
112	Lever seat	1
113	Handle lever	1
114	M6x10 Slotted flat end set screw	1
115	Bush	1
116	51104 Thrust ball bearing	1

## 03 Table part

No.	Name	Qty
117	2.5×25.5×140 Spring	1
118	m=3.15 z=1 Worm	1
119	51102 Thrust ball bearing	1
120	Bush	1
121	Nut	1
122	8×40 Taper pin	2
123	Bracket	1
124	Bush	1
125	Bracket	1
126	4×25 Taper pin	2

MACHINERYHOUSE

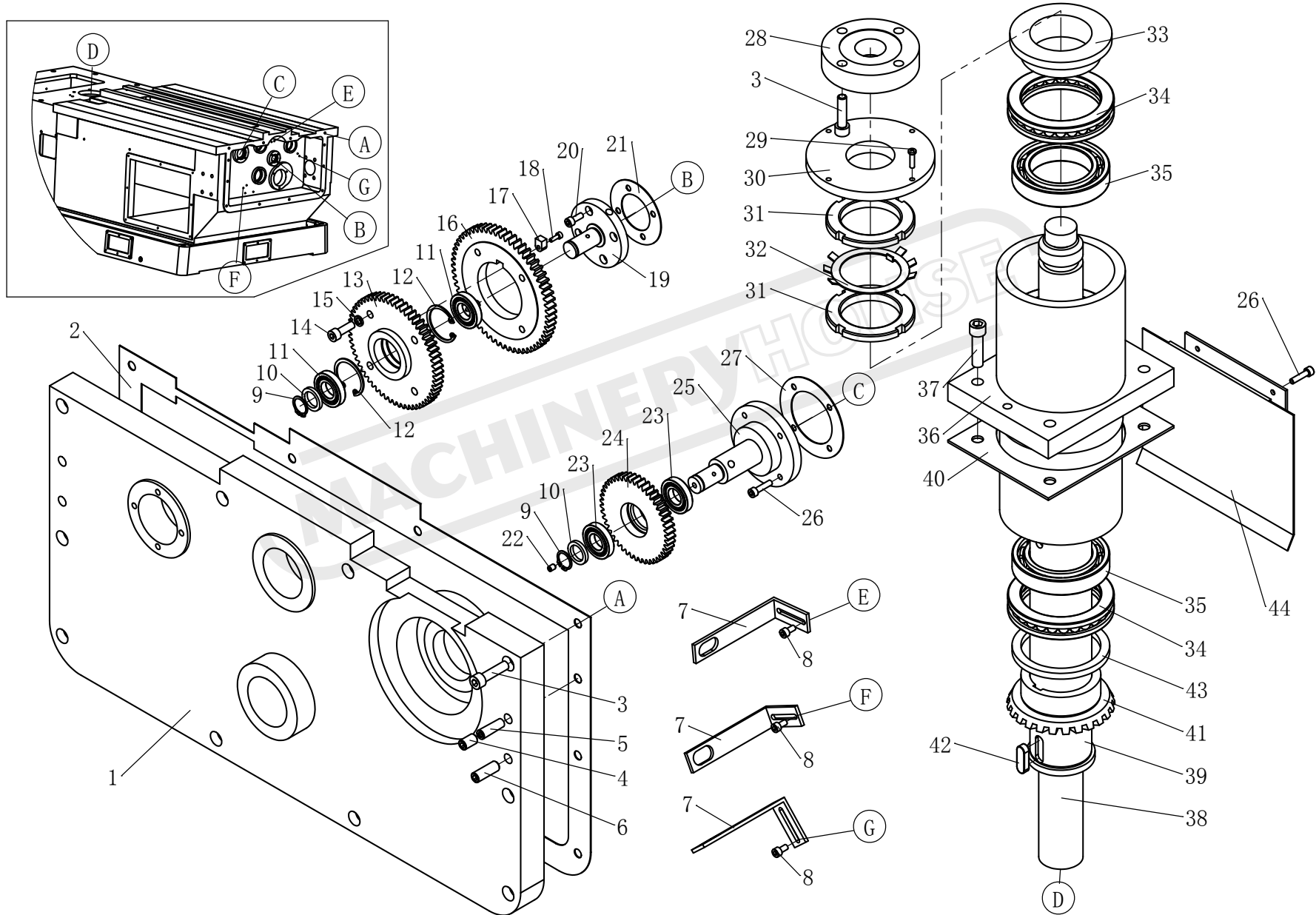

04 Feed Part



04 Feed Part

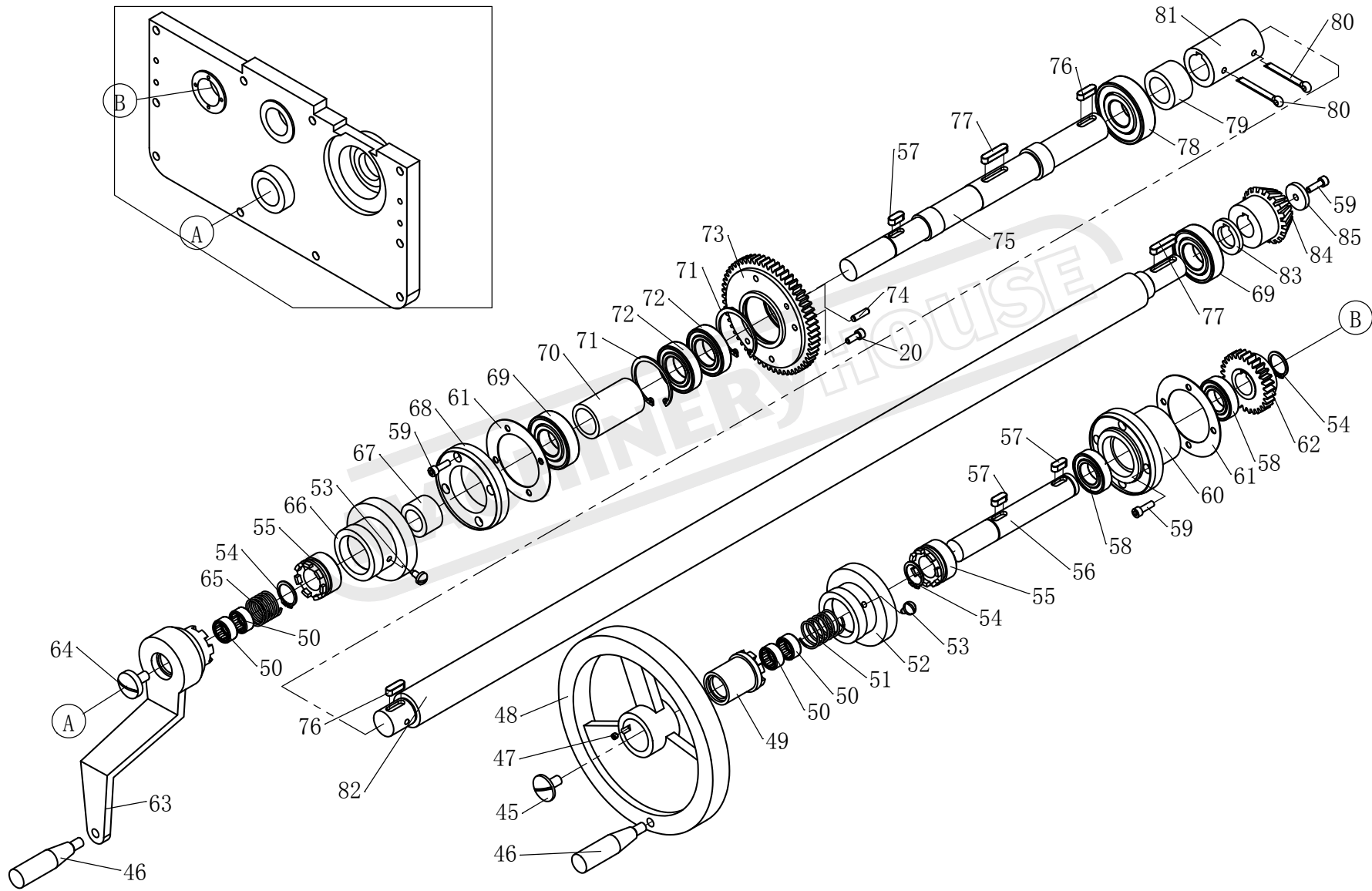

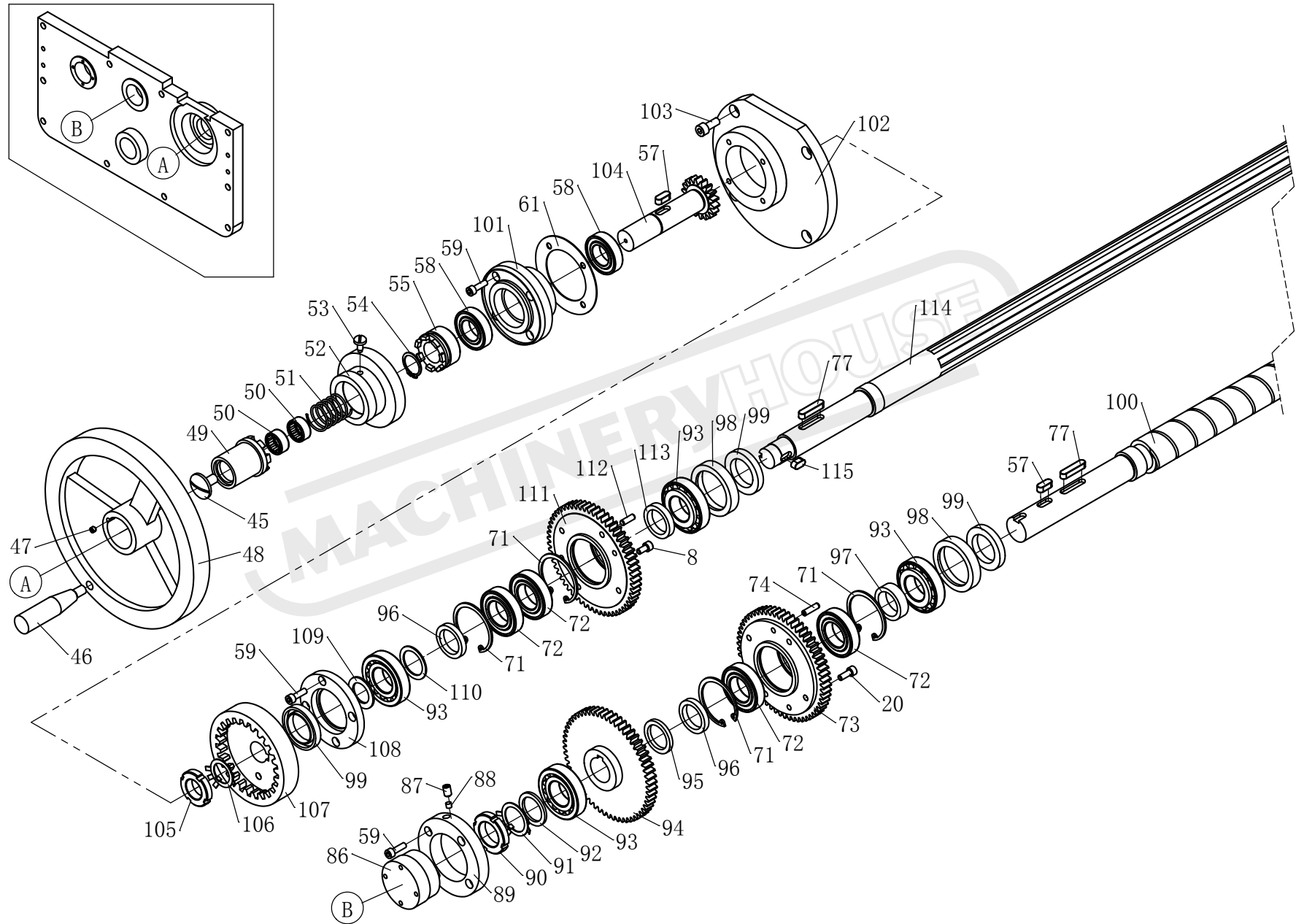

04 Feed Part

# 04 Feed Part

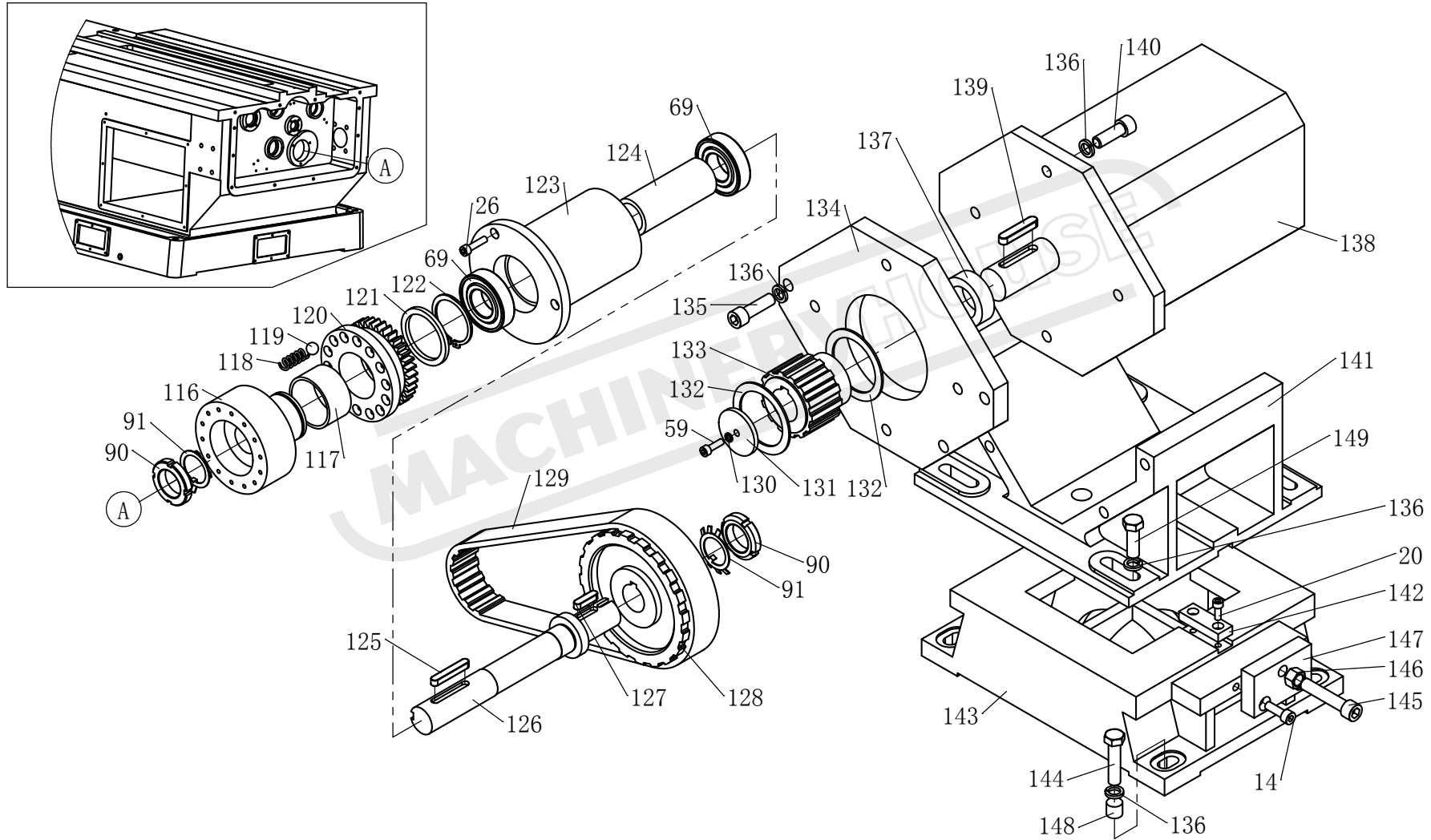

## 04 Feed part

No.	Name	Qty
1	Lid support	1
2	Washer	1
3	M10×40 Hexagon socket head cap screw	14
4	M12×20 Set screw	2
5	10×35 Taper pin	2
6	M12×35 Set screw	2
7	Bent plate	3
8	M6×12 Hexagon socket head cap screw	10
9	20 Circlip for shaft	4
10	Washer	2
11	6004 20×42×12 Bearing	4
12	42 Circlip for hole	2
13	m=2.25 z=60 Gear	1
14	M8×25 Hexagon socket head cap screw	6
15	8 Helical spring lockwasher	4
16	m=2.5 z=60 Gear	1
17	Key	1
18	M4×12 Hexagon socket head cap screw	1
19	Shaft	1
20	M6×16 Hexagon socket head cap screw	16
21	Washer	1
22	M6×8 Set screw	1
23	6004-Z 20×42×12 Bearing	2
24	m=2.25 z=46 Gear	1
25	Shaft	1
26	M6×25 Hexagon socket head cap screw	9
27	Washer	1
28	Connector	1
29	M5×20 Cross recessed pan head screw	4

## 04 Feed part

No.	Name	Qty
30	Pressure cover	1
31	M68x2 Lock nut	2
32	68 Check washer	1
33	Collar	1
34	51118 90x120x22 Bearing	2
35	6014 70x110x20 Bearing	2
36	Bush	1
37	M12x45 Hexagon socket head cap screw	4
38	Lead screw	1
39	Nut	1
40	Adjustable washer	1
41	m=3 z=40 Gear	1
42	12x36 Flat key	1
43	Washer	1
44	Baffle plate	1
45	Screw	2
46	M10x80 Handle	3
47	M6x6 Slotted taper end set screw	2
48	Handwheel	2
49	Clutch	2
50	2516 25x32x16 Bearing	6
51	2x28x40 Spring	2
52	Dial	2
53	Screw	3
54	25 Circlip for shaft	4
55	Clutch	3
56	Shaft	1
57	8x20 Flat key	5
58	6005-2Z 25x47x12 Bearing	4

## 04 Feed part

No.	Name	Qty
59	M6x20 Hexagon socket head cap screw	26
60	Bearing seat	1
61	Waher	3
62	m=2.25 z=39 Gear	1
63	Handle	1
64	Screw	1
65	2x28x28 Spring	1
66	Dial	1
67	Bush	1
68	Pressure cover	1
69	6206-2Z 30x62x16 Bearing	4
70	Spacer	1
71	55 Circlip for hole	6
72	6006-2Z 30x55x13 Bearing	6
73	m=2.25 z=58 Gear	2
74	6x22 Cylindrical pin with internal thread	4
75	Shaft	1
76	8x25 Flat key	2
77	8x36 Flat key	4
78	6306-2Z 30x72x19 Bearing	1
79	Collar	1
80	6.3x50 Split pin	2
81	Collar	1
82	Shaft	1
83	Washer	1
84	m=3 z=20 Gear	1
85	Waher	1
86	Blind nut	1
87	M8x12 Screw	1

## 04 Feed part

No.	Name	Qty
88	Copper washer	1
89	Cover	1
90	M30×1.5 Lock nut	3
91	30 Check washer	3
92	Washer	1
93	30206 30×62×16 Bearing	4
94	m=2.25 z=58 Gear	1
95	Collar	1
96	Collar	3
97	Collar	1
98	Oil seal seat	2
99	355208 Seal	3
100	Lead screw	1
101	Bearing seat	1
102	Eccentric cover	1
103	M8×20 Hexagon socket head cap screw	4
104	m=2.5 z=18 Gear	1
105	Lock nut	1
106	24 Check washer	1
107	m=2.5 z=36 Gear	1
108	Pressure cover	1
109	Washer	1
110	Washer	1
111	m=2.25 z=58 Gear	1
112	6×18 Cylindrical pin with internal thread	2
113	Washer	1
114	Spline shaft	1
115	8×16 Flat key	1
116	Clutch seat	1

## 04 Feed part

No.	Name	Qty
117	Collar	1
118	2x10x30 Spring	14
119	12 Steel ball	14
120	m=2.5 z=35 Gear	1
121	Washer	1
122	50 Circlip for shaft	1
123	Supporting bush	1
124	Bush	1
125	8x50 Flat key	1
126	Shaft	1
127	8x30 Flat key	2
128	Synchronous pulley	1
129	310H-40 Synchronous belt	1
130	6 Spring washer	4
131	Back cover	1
132	Collet	2
133	Synchronous pulley	1
134	Connecting plate	1
135	M12x40 Hexagon socket head cap screw	4
136	12 Spring washer	12
137	Collet	1
138	APM-SF20M Servo motor	1
139	10x50 Flat key	1
140	M12x35 Hexagon socket head cap screw	4
141	Supporting seat	1
142	Key	2
143	Connecting seat	1
144	M12x50 Hexagon bolt	4
145	M12x60 Hexagon socket head cap screw	1



## 04 Feed part

No.	Name	Qty
146	M12 Nut	1
147	Supporting plate	1
148	Plug	4
149	M12×35 Hexagon bolt	4

MACHINERYHOUSE

# 06 Headstock part

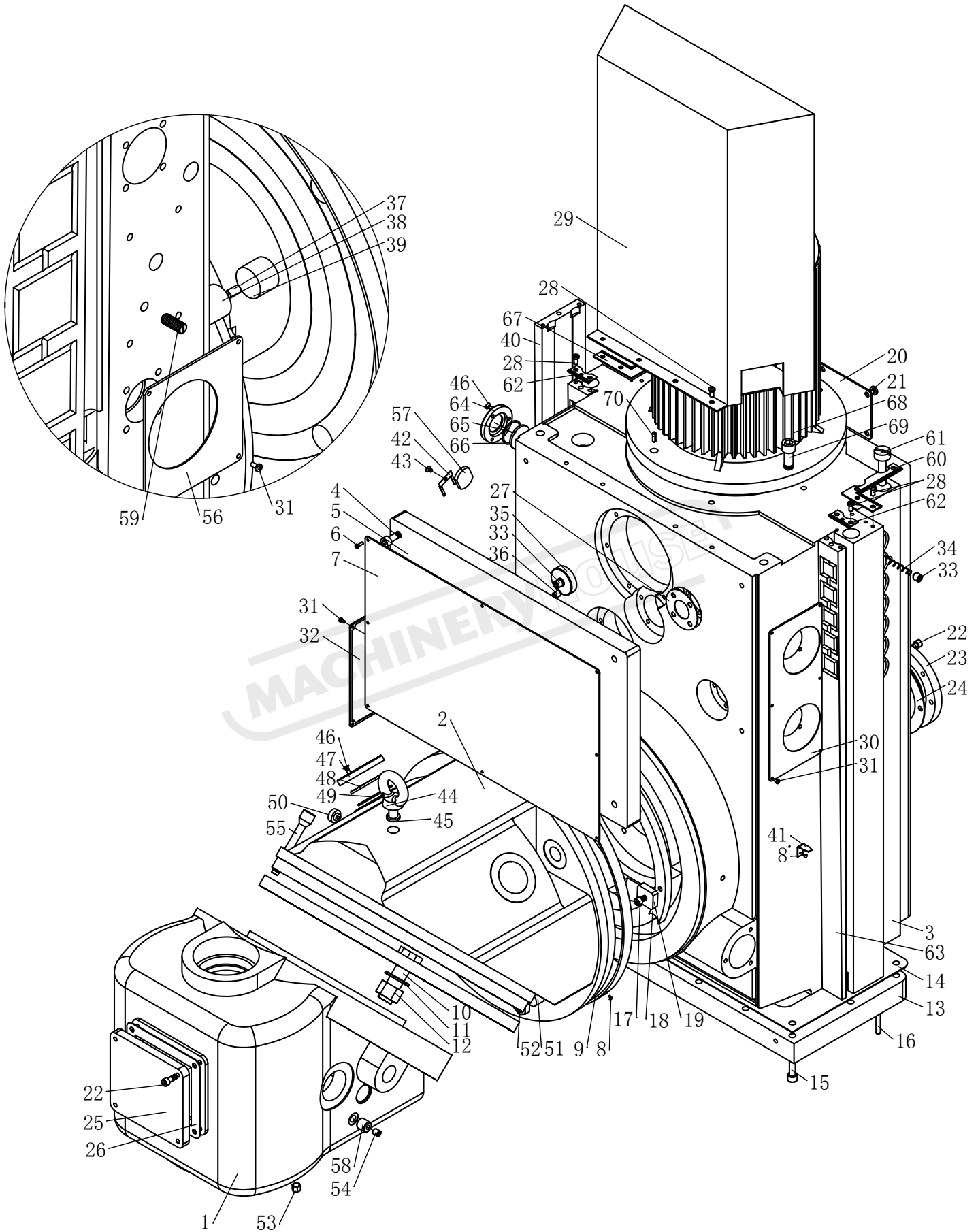

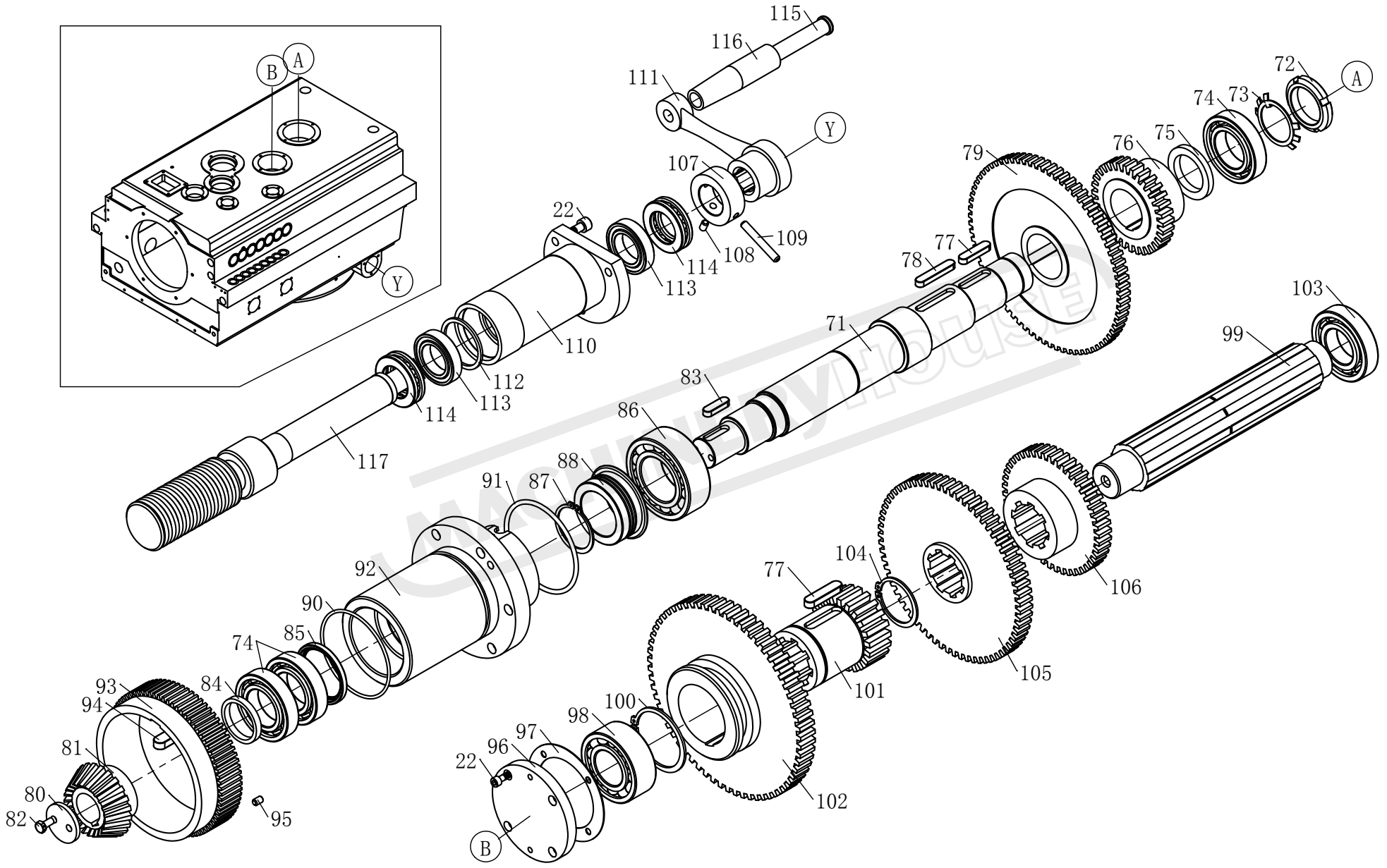

06 Headstock part

# 06 Headstock part

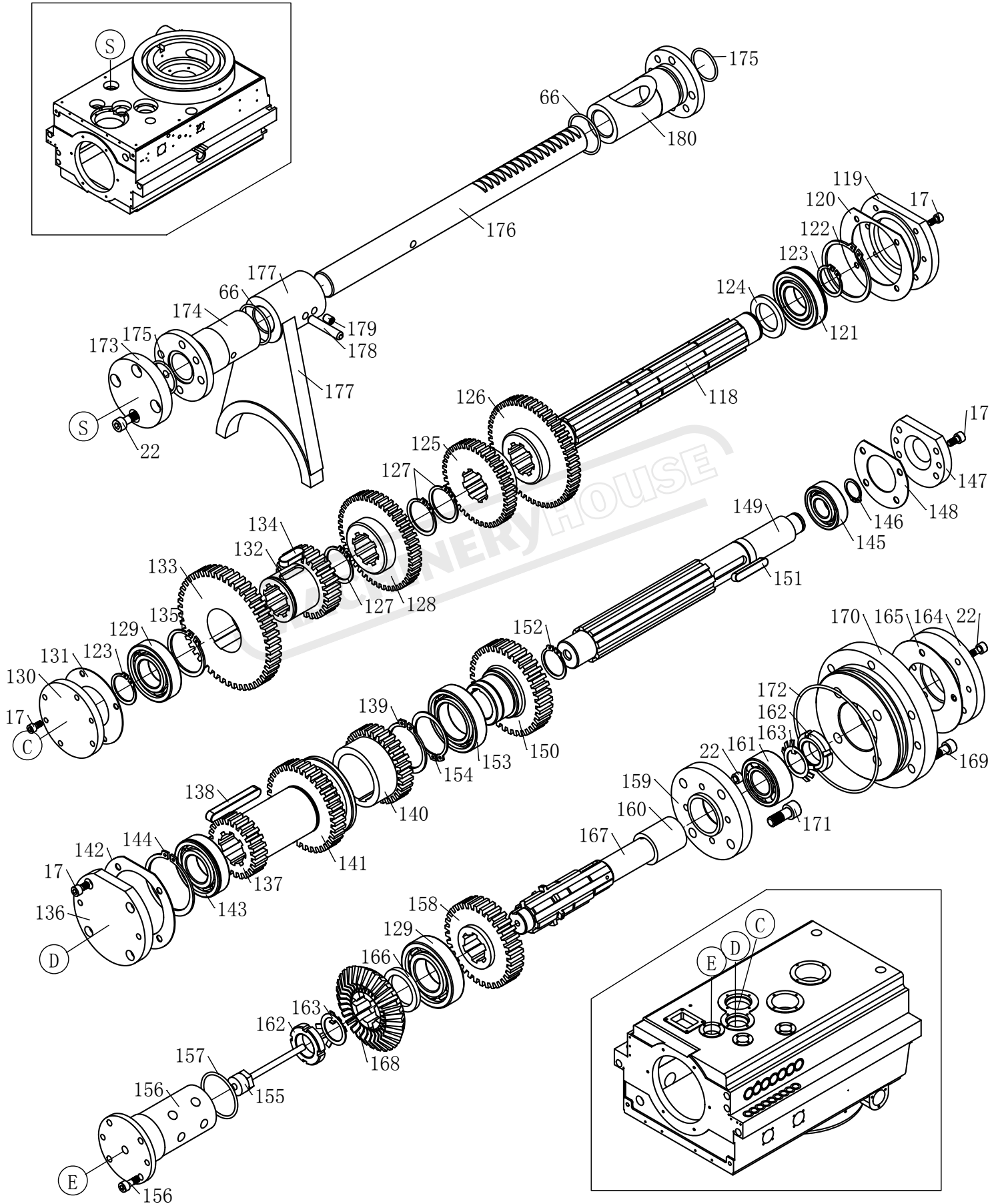

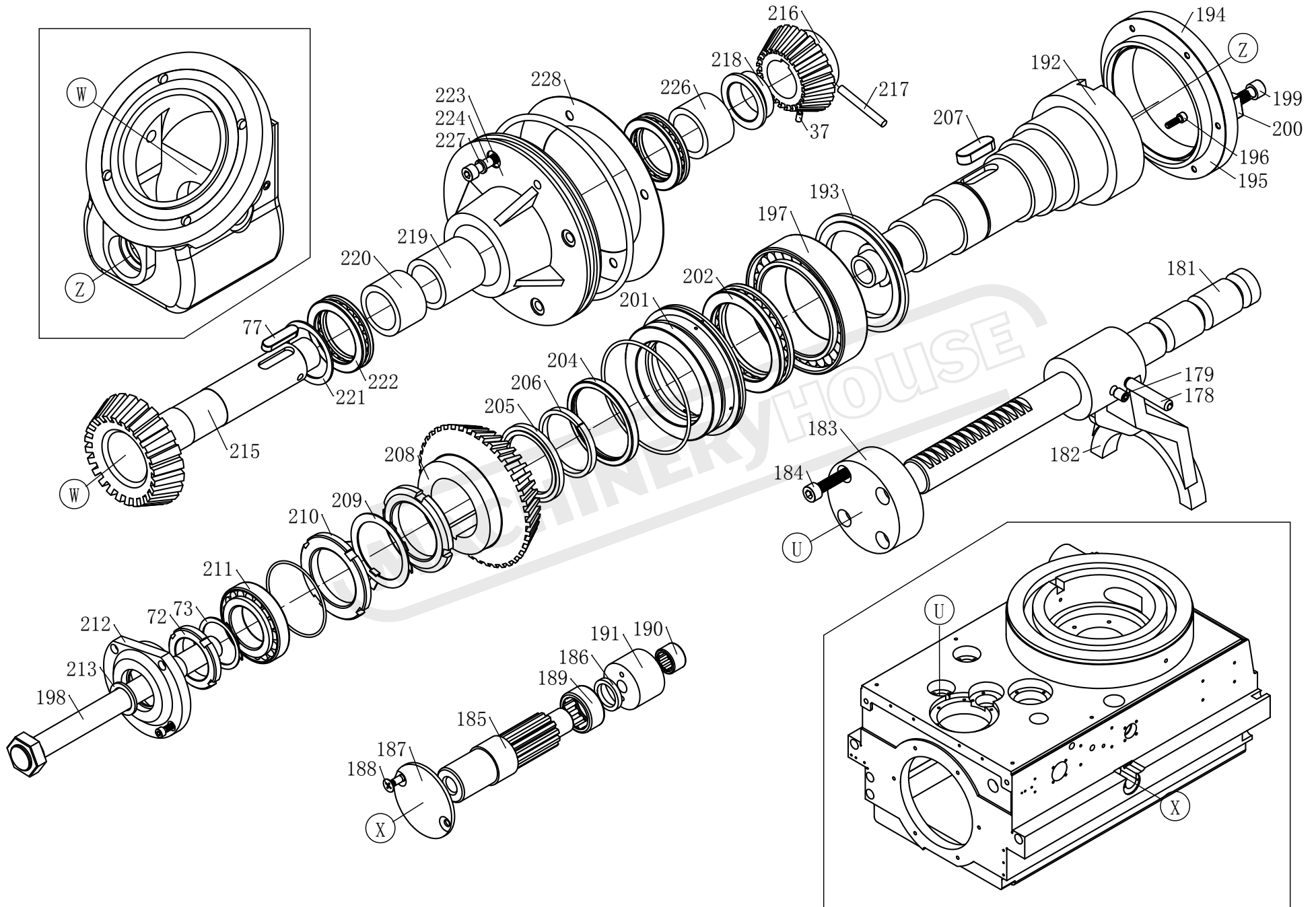

06 Headstock part

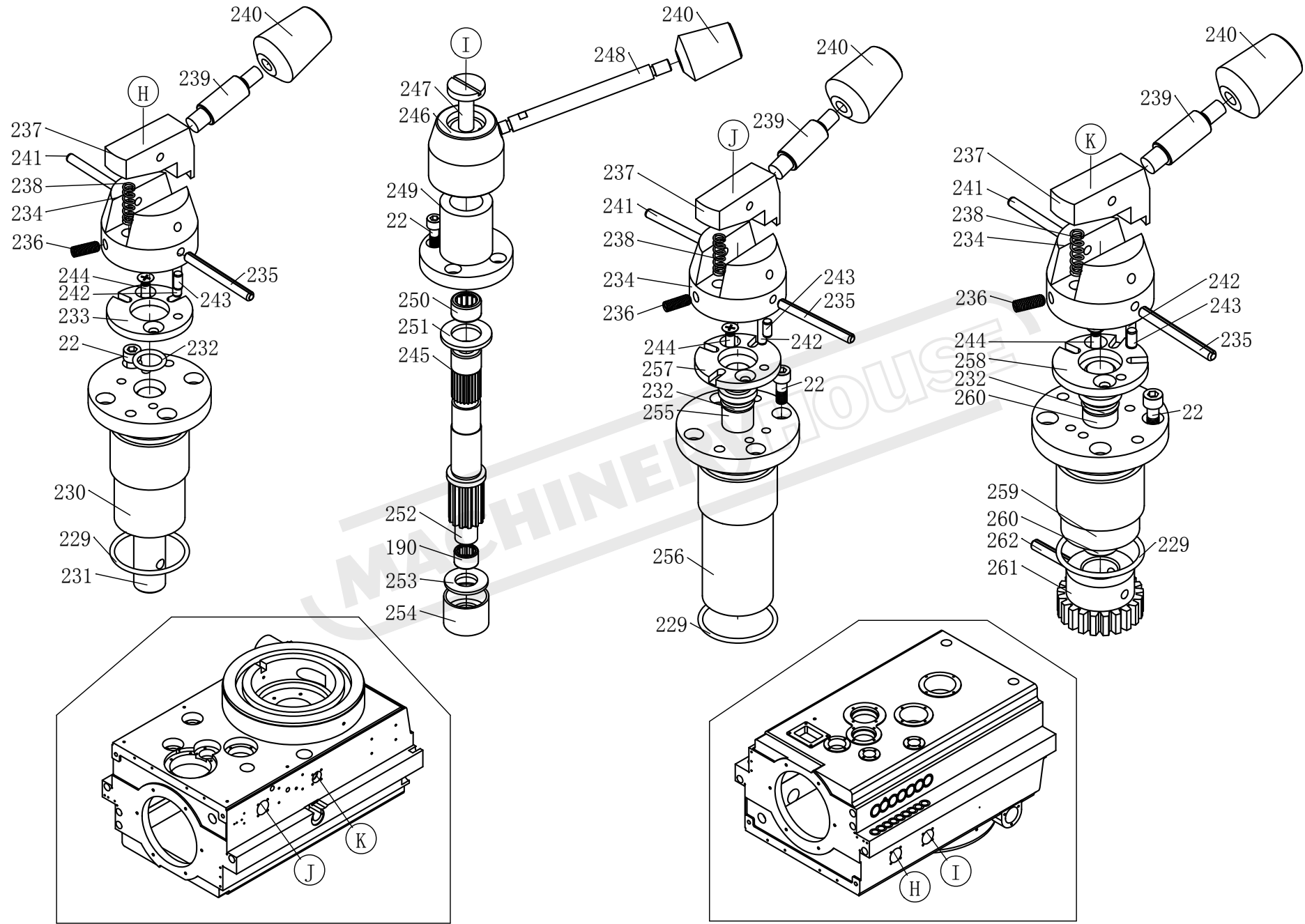

06 Headstock part

# 06 Headstock part

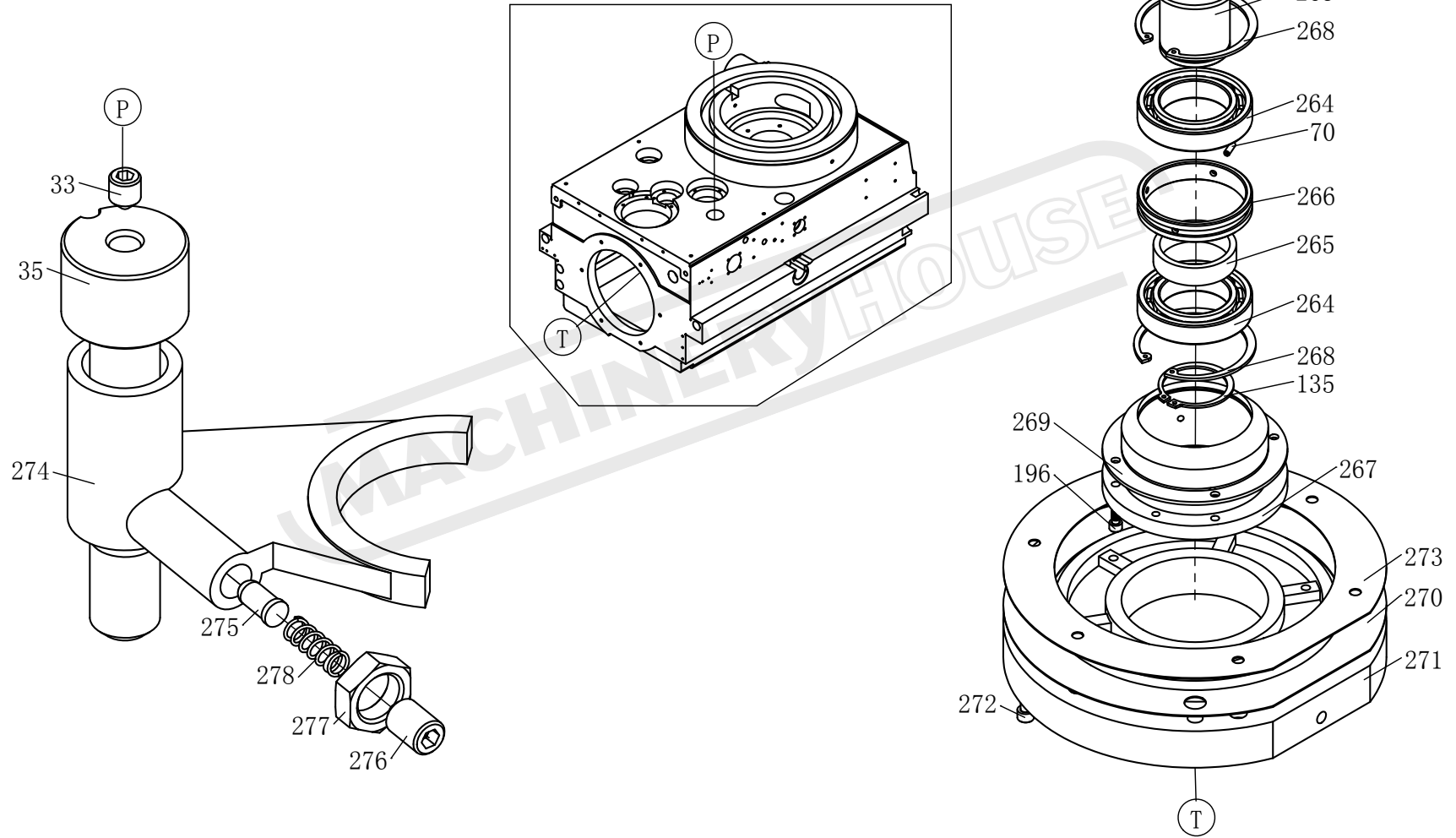

## 06 Headstock Part

No.	Name	Qty
1	Headstock	1
2	Rotary head	1
3	Gearbox	1
4	8x25 Hexagon socket head cap screw	4
5	Scutcheon	1
6	M3x10 Screw	14
7	Scutcheon	1
8	M2x6 Rivet	5
9	Scale	2
10	Screw	1
11	20 Flat washer	8
12	M20 Nut	8
13	Cover	1
14	Washer	1
15	8x35 Hexagon socket head cap screw	12
16	6x50 Cylindrical pin	3
17	M6x12 Hexagon socket head cap screw	32
18	Plate	1
19	Plate	1
20	Cover	1
21	M6x8 Screw	4
22	M6x16 Hexagon socket head cap screw	54
23	Cover	1
24	Washer	1
25	Cover	1
26	Washer	1
27	Washer	1
28	M5x10 Screw	14
29	Cover	1



## 06 Headstock Part

No.	Name	Qty
30	Indicator drop	1
31	M3x6 Screw	14
32	Speed plate	1
33	M10x12 Screw	2
34	1.2x6.3x85 Spring	1
35	Sliding bar	1
36	M8x10 Screw	2
37	M6x12 Screw	2
38	Rack shaft	1
39	Plug	1
40	Gib	1
41	Index	1
42	Spring washer	1
43	M4x6 Screw	1
44	M12 Ringbolt	1
45	12 Spring washer	1
46	M4x16 Screw	2
47	Oil scale	1
48	Glass	1
49	50x1.8 O-ring	1
50	A10 Oil scale	1
51	Taper pin	1
52	M16 Nut	1
53	M10 Oil plug	1
54	8 Oil cup	1
55	Taper pin	1
56	Indicator drop	1
57	Clamping plate	1
58	Plug	1

## 06 Headstock Part

No.	Name	Qty
59	M8x20 Screw	1
60	Wiper	1
61	Screw	1
62	Wiper	2
63	Gib	2
64	Oil scale	1
65	Glass	1
66	31.5x1.8 O-ring	3
67	Wiper	1
68	7.5Kw-B5 Motor	1
69	12x40 Hexagon socket head cap screw	1
70	4x15 Elastic pin	2
71	Shaft	1
72	M50x1.5 Nut	2
73	50 Lock washer	2
74	6210 Bearing	3
75	Collar	1
76	m=3.5 z=32 Gear	1
77	12x50 Key	3
78	12x63 Key	1
79	m=3.5 z=74 Gear	1
80	Cover	1
81	m=4 z=23 Helical gear	1
82	8x16 Bolt	1
83	12x40 Key	1
84	Washer	1
85	80x55x8 Seal ring	1
86	3212 Bearing	9
87	60 Circlip for shaft	1

## 06 Headstock Part

No.	Name	Qty
88	Bush	1
89	M8x30 Hexagon socket head cap screw	1
90	112x3.55 O-ring	1
91	115x5.3 O-ring	1
92	Bearing housing	1
93	m=2.5 z=75 Worm wheel	1
94	16x40 Key	1
95	M8x12 Screw	2
96	Cover	1
97	Washer	1
98	3208 Bearing	1
99	Spline shaft	1
100	68 Circlip for shaft	1
101	m=3.5 z=63 Gear	1
102	m=3.5 z=21 Gear	1
103	6208 Bearing	1
104	52 Circlip for shaft	1
105	m=3 z=67 Gear	1
106	m=3 z=45 Gear	1
107	Bush	1
108	M5x8 Screw	2
109	5x40 Elastic pin	1
110	Bearing housing	1
111	Handle	1
112	Washer	1
113	61905-2Z Bearing	2
114	HK51105 Bearing	2
115	Handle	1
116	Grip	1

## 06 Headstock Part

No.	Name	Qty
117	Worm	1
118	Spline shaft	1
119	Cover	1
120	Washer	1
121	6207-ZN Bearing	1
122	72 Circlip for shaft	1
123	35 Circlip for shaft	2
124	Washer	1
125	m=2.5 z=40 Gear	1
126	m=2.5 z=52 Gear	1
127	42 Circlip for shaft	3
128	m=2.5 z=46 Gear	1
129	6207 Bearing	2
130	Cover	1
131	Washer	1
132	m=3 z=26 Gear	1
133	m=3 z=48 Gear	1
134	12x35 Key	1
135	55 Circlip for shaft	2
136	Cover	1
137	m=2.5 z=24 Gear	1
138	10x70 Key	1
139	50 Circlip for shaft	1
140	m=2.5 z=30 Gear	1
141	m=2.5 z=36 Gear	1
142	Washer	1
143	6206-ZN Bearing	1
144	62 Circlip for shaft	1
145	6204 Bearing	1

## 06 Headstock Part

No.	Name	Qty
146	20 Circlip for shaft	1
147	Cover	1
148	Washer	1
149	Spline shaft	1
150	m=2.5 z=36 Gear	1
151	8x45 Key	1
152	30 Circlip for shaft	1
153	6009 Bearing	1
154	45 Circlip for shaft	1
155	Nozzle	1
156	Oil distributor	1
157	45x2.65 O-ring	1
158	m=2.5 z=34 Gear	1
159	Flange	1
160	Bush	1
161	3205 Bearing	1
162	M25x1.5 Nut	2
163	25 Lock washer	2
164	Cover	1
165	Washer	1
166	Washer	1
167	Spline shaft	1
168	m=3 z=30 Helical gear	1
169	8x20 Hexagon socket head cap screw	1
170	Cover	1
171	10x25 Hexagon socket head cap screw	1
172	112x2.65 O-ring	1
173	Cover	1
174	Cover	1

## 06 Headstock Part

No.	Name	Qty
175	25x1.8 O-ring	2
176	Shifter rod	1
177	Shifting fork	1
178	6x36 Elastic pin	2
179	M6x8 Screw	3
180	Housing	1
181	Shifter rod	1
182	Shifting fork	1
183	Cover	1
184	M6x30 Hexagon socket head cap screw	4
185	Worm wheel	1
186	Washer	1
187	Cover	1
188	M4x10 Screw	1
189	HK2520 Bearing	5
190	HK1512 Bearing	2
191	Bearing housing	1
192	Spindle	1
193	Collar	1
194	Cover	1
195	Washer	1
196	M6x20 Hexagon socket head cap screw	12
197	3020K/P5 Bearing	1
198	Drawbar	1
199	M12x25 Hexagon socket head cap screw	1
200	Key	1
201	Pressure plate	1
202	HK51118 Bearing	1
203	128x3.55 O-ring	1

## 06 Headstock Part

No.	Name	Qty
204	FB80x100x10 seal ring	1
205	Collar	1
206	Collar	1
207	18x50 Key	1
208	m=4 z=41 Helical gear	1
209	68 Lock washwer	1
210	M68x2 Nut	2
211	30210/P5 Bearing	1
212	Cover	1
213	Washer	1
214	85x2.65 O-ring	1
215	m=4 z=31 Helical gear	1
216	m=4 z=24 Helical gear	1
217	8x70 Taper pin	1
218	Bush	1
219	Bush	1
220	Bush	1
221	Washer	1
222	60x72x40 Combined bearing	1
223	Cover	1
224	10x40 Hexagon socket head cap screw	4
225	206x7 O-ring	1
226	Collar	1
227	10 Spring washer	1
228	Washer	1
229	40x2.65 O-ring	3
230	Cover	1
231	Shaft	1
232	14x2.65 O-ring	3

## 06 Headstock Part

No.	Name	Qty
233	Locating plate	1
234	Lever boss	3
235	5x55 Elastic pin	3
236	M6x16 Screw	3
237	Lever	3
238	1x6x25 Spring	3
239	Lever	3
240	B-M8x25 grip	4
241	5x50 Cylindrical pin	3
242	5x30 Cylindrical pin	3
243	5 x10 Cylindrical pin	3
244	M5x16 Screw	6
245	Collar	1
246	Handle seat	1
247	Screw	1
248	Handle lever	1
249	Bearing housing	1
250	HK2020	1
251	Washer	1
252	m=1.5 z=13 Gear shaft	1
253	Washer	1
254	Bearing housing	1
255	Shaft	1
256	Cover	1
257	Locating plate	1
258	Locating plate	1
259	Cover	1
260	Shaft	1
261	m=2 z=21 Gear	1





# 09 10 Cooling & lubricating parts

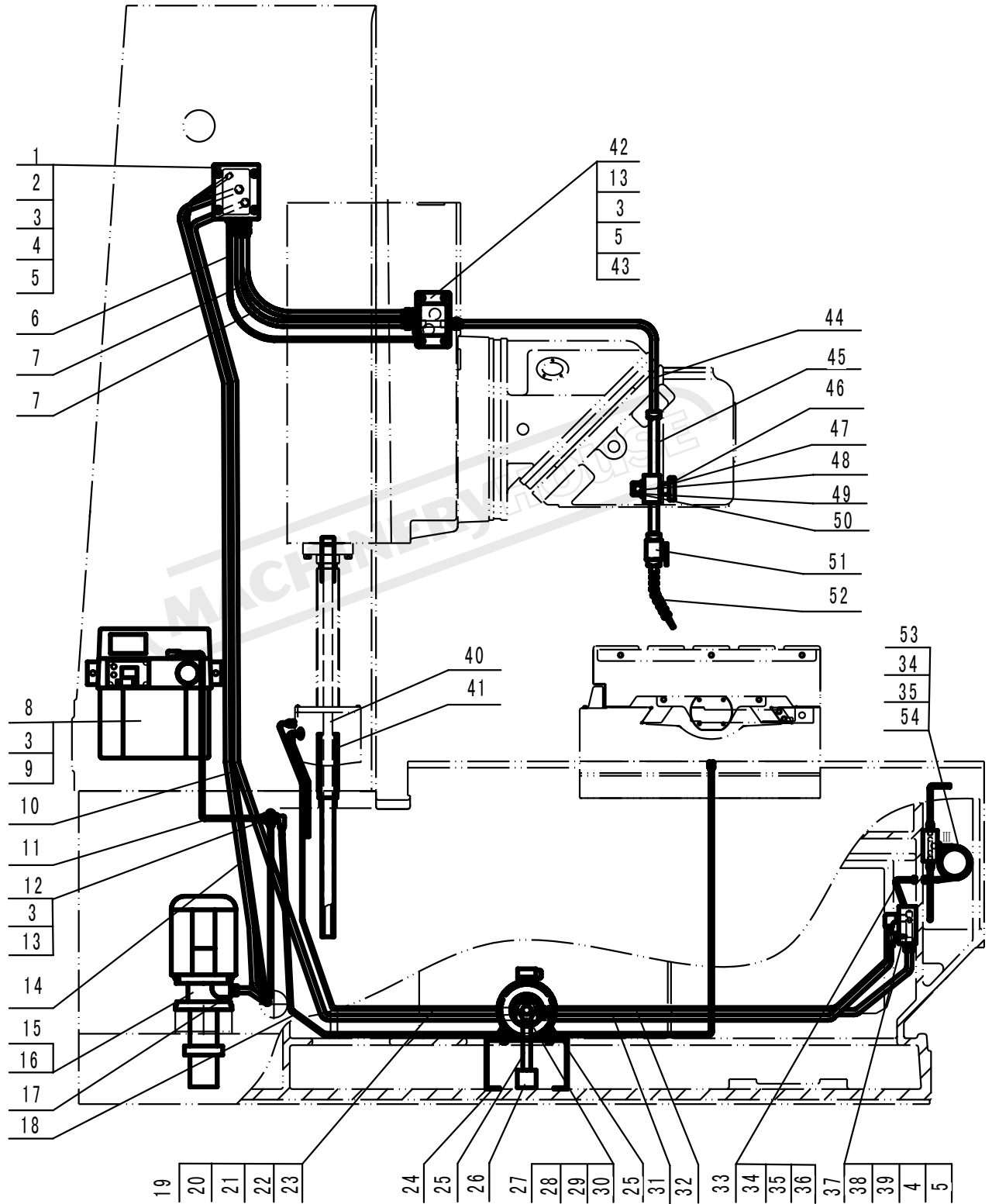

# 09 10 Cooling & lubricating parts

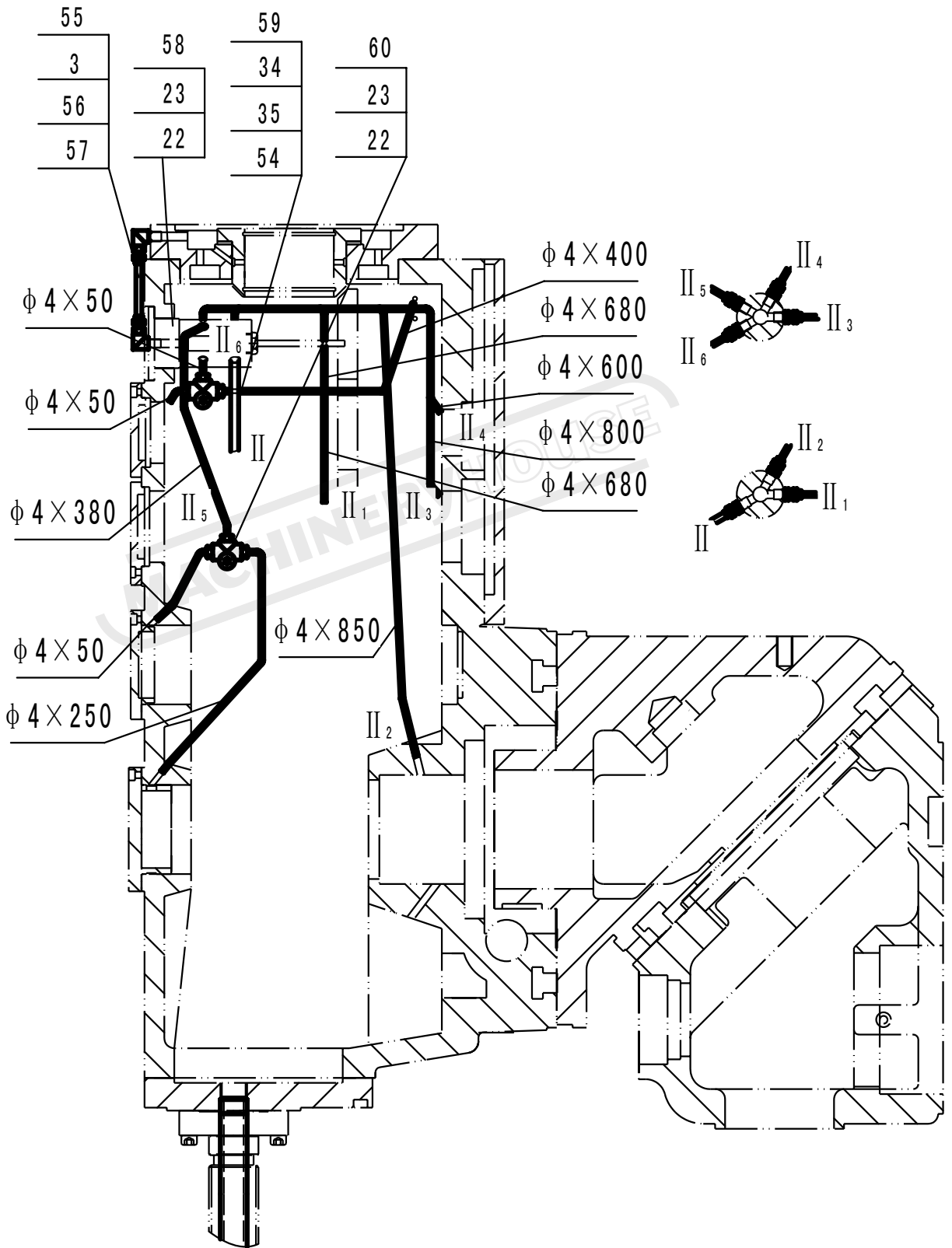

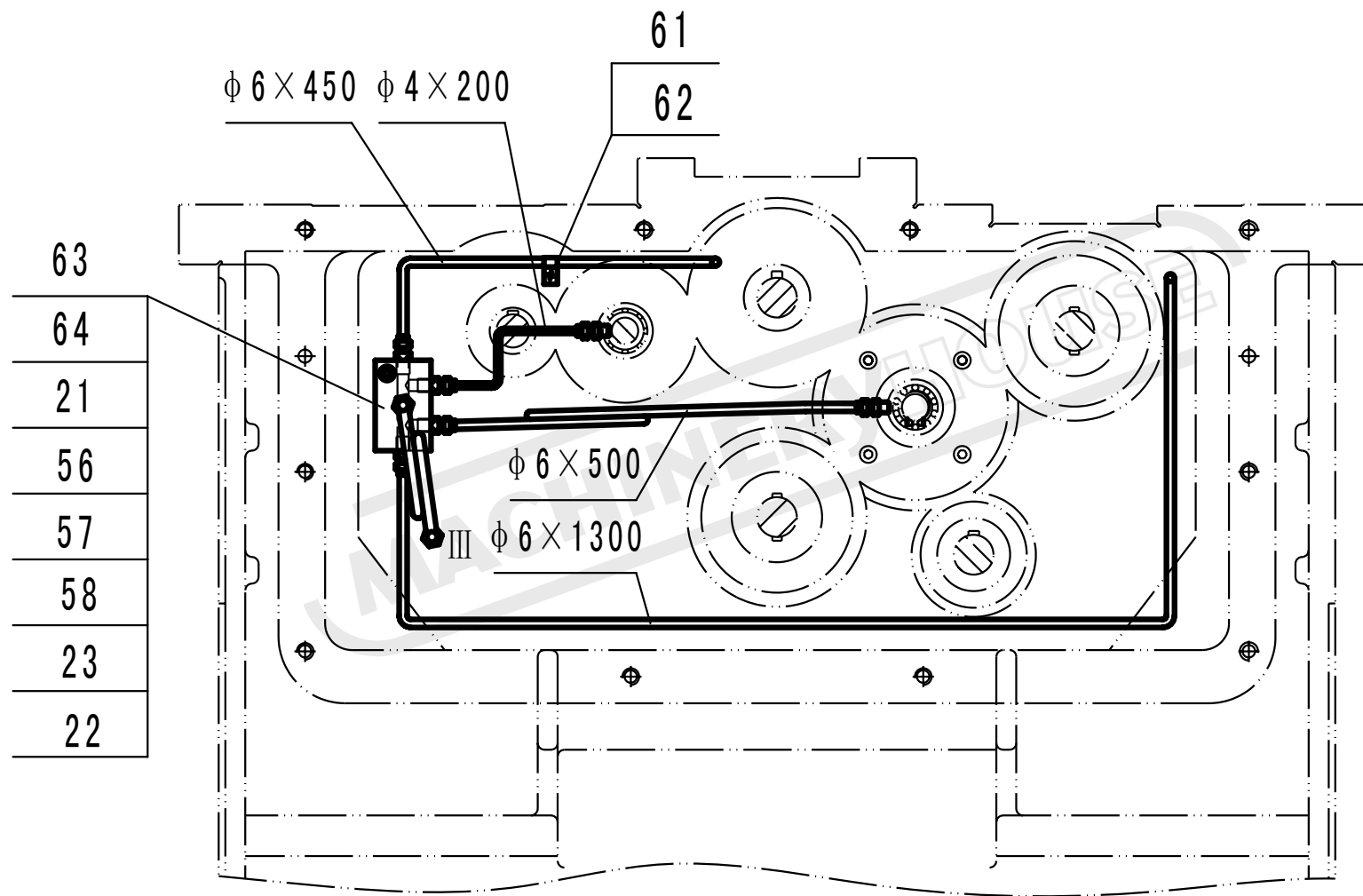

09 10 Cooling & Lubricating parts

09 10 Cooling & Lubricating parts

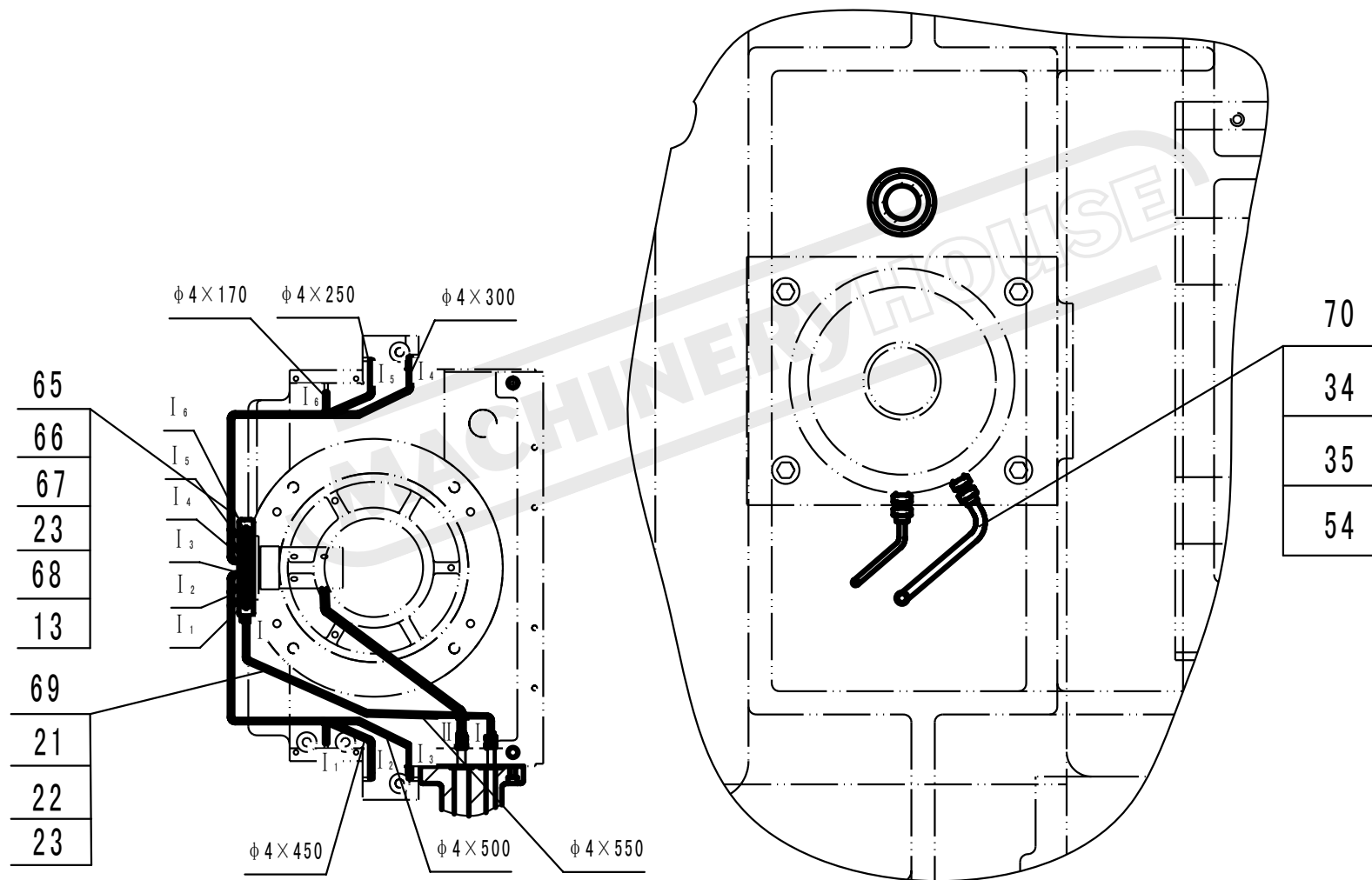

# 09 10 Cooling & lubricating parts

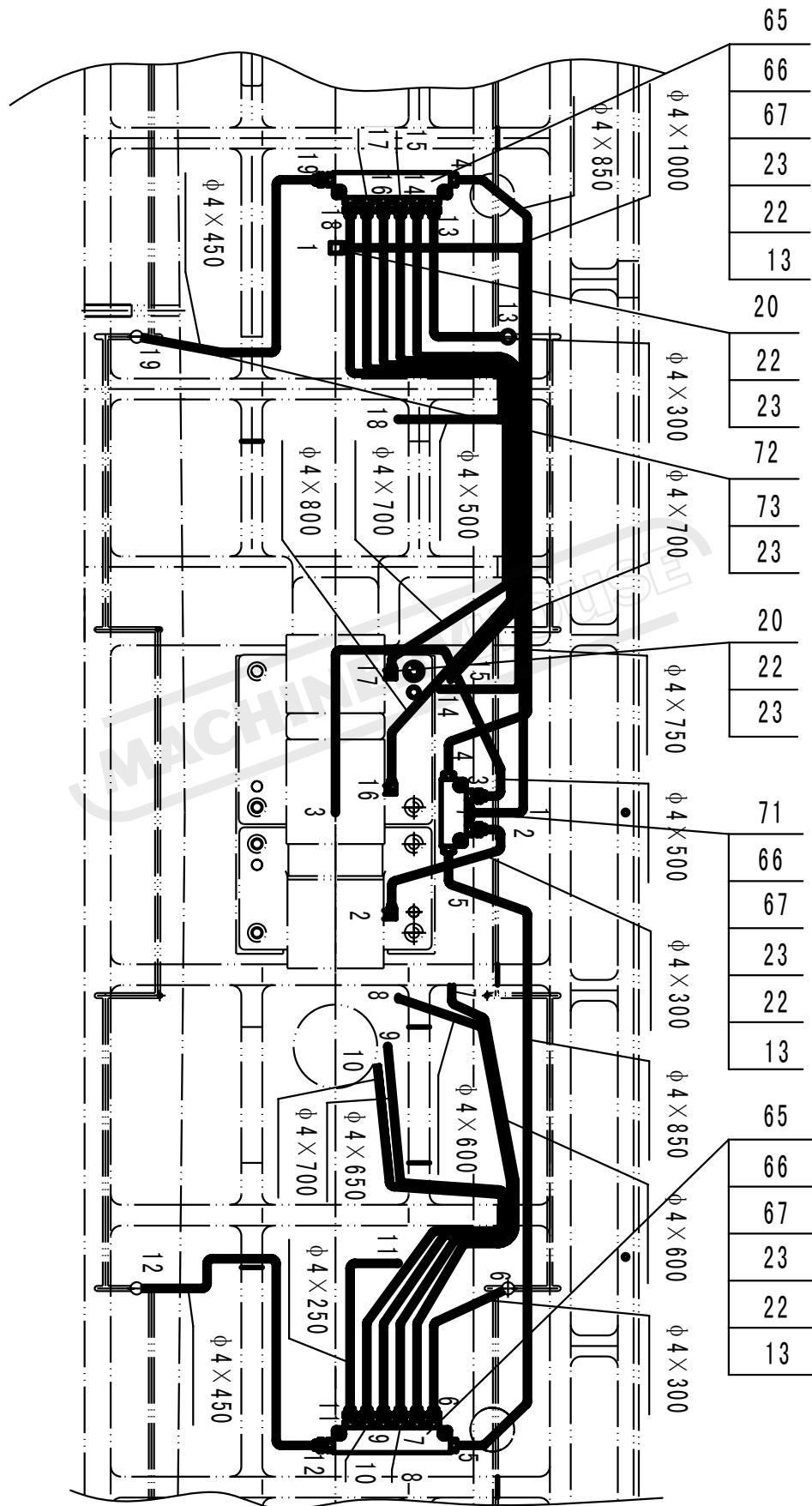

## 09 10 Cooling & Lubricating parts

No.	Name	Qty
1	Distribution	1
2	M8x60 Hexagon socket head cap screw	4
3	M10×1/M10×1 Elbow	6
4	G14- M18×1.5 Pipe joint	3
5	G14- M18×1.5 Pipe joint	6
6	A- φ 6×1200 Tube	1
7	Hose assembly	2
8	M10x1 Lubrication pump	1
9	M6x16 Cross recessed pan head screw	2
10	A- φ 6×2600 Flexible pipe	1
11	A- φ 6×450 Flexible pipe	1
12	M10×1 Distribution	1
13	M6x25 Hexagon socket head cap screw	13
14	Hose assembly	1
15	M8x65 Hexagon socket head cap screw	4
16	550W Coolant pump	1
17	Adapter	1
18	A- φ 6×2500 Flexible pipe	1
19	φ 14/ φ 3×2500 Copper pipe	1
20	M8×1/M10×1 Elbow	6
21	M10×1/M10×1 Elbow	6
22	Φ 4.2-M8×1 Oil pipe connecting	27
23	φ 6/ φ 4.1 Sleeve	49
24	Bracket	1
25	Pipe	1
26	Filter	1
27	120W Cycloid pump	1
28	M6×20 Hexagonal bolt	4
29	M6 Hexagon nut	4

## 09 10 Cooling & Lubricating parts

No.	Name	Qty
30	6 Spring washer	4
31	M12×1/G 1/8 Hose assembly	7
32	M12×1/G 1/8 Hose assembly	1
33	φ 8/ φ 6×350 Copper pipe	1
34	M12×1/ G 1/8 Straight joint	7
35	φ 10/ φ 8.1 Sleeve	7
36	φ 8.2-M12×1 Oil pipe joint	7
37	Distribution	1
38	M6×45 Hexagon socket head cap screw	2
39	M8×1/M10×1 Elbow	6
40	Oil pipe	1
41	Pipe	1
42	Distribution	1
43	2.65× φ 20 O-ring seal	2
44	Hose assembly	1
45	Connecting tube	1
46	Knurled screw	1
47	Supporting block	1
48	Supporting pipe	1
49	Clamping bush	1
50	Bush	1
51	G 3/8 Globe valve	1
52	G3/8" Copper tube	1
53	φ 8/ φ 6×400 Copper tube	1
54	φ 8.2-M12×1 Oil pipe joint	6
55	φ 6/ φ 4×180 Copper tube	1
56	φ 8/ φ 6.1 Sleeve	6
57	φ 6.1-M10×1 Oil pipe joint	6
58	M8×1/G 1/8 Straight joint	8



## 09 10 Cooling & Lubricating parts

No.	Name	Qty
59	$\phi$ 8/ $\phi$ 6 $\times$ 180 Copper tube	1
60	M8 $\times$ 1 Distribution	2
61	$\phi$ 4 Pipe clamp	5
62	M5 $\times$ 8 Cross recessed pan head screw	5
63	Distribution	1
64	M6 $\times$ 35 Hexagon socket head cap screw	2
65	M8 $\times$ 1 Distribution	3
66	Gauge	22
67	$\phi$ 4.2-M8 $\times$ 1 Collar nut	22
68	M8 $\times$ 1 Oil plug	1
69	$\phi$ 4/ $\phi$ 3 $\times$ 850 Copper tube	1
70	$\phi$ 8/ $\phi$ 6 $\times$ 400 Copper tube	1
71	Distribution	1
72	M8 $\times$ 1 Elbow	4

# 01 Column & Base part

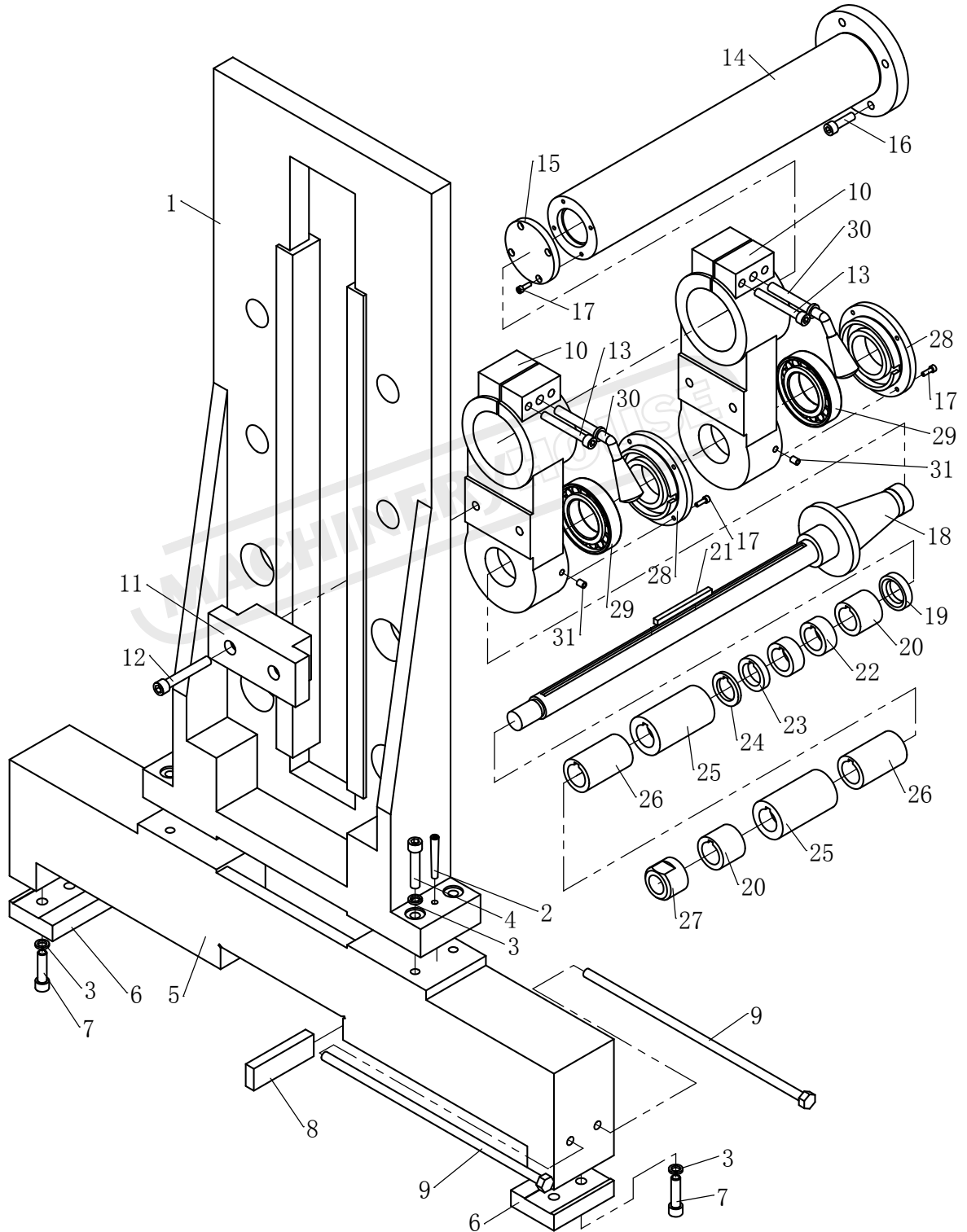

## F Accessories part

No.	Name	Qty
1	Bracket	1
2	8x65 Taper pin	2
3	12 Spring washer	8
4	M12x60 Hexagon socket head cap screw	4
5	Boss	1
6	Pressure plate	2
7	M12x45 Hexagon socket head cap screw	4
8	Gib	1
9	Screw	2
10	Hanger	2
11	Clamping plate	1
12	M12x80 Hexagon socket head cap screw	4
13	M10x80 Hexagon socket head cap screw	4
14	Support	1
15	Cover	1
16	M10x35 Hexagon socket head cap screw	4
17	M5x16 Hexagon socket head cap screw	8
18	Cutter arbor	1
19	Collar	1
20	Collar	2
21	Key	1
22	Collar	2
23	Collar	1
24	Collar	1
25	Collar	2
26	Collar	2
27	Nut	1
28	Cover	2
29	N211E 55x100x21 Bearing	2

## F Accessories part

No.	Name	Qty
30	Handlebar	2
31	8 Oil cup	2

MACHINERYHOUSE

## DC lubricator

DC lubricator includes a motor-driven gear pump of reasonable structure, excellent performance, complete functions, wide applicability, good self absorption and high volume efficiency. Reservoir capacity is in 2L and 3L, This kind of pump is equipped with level switch and pressure switch can be provided according to different applications. These are connected with BMTC or HLTC programmed controller on the pump, or programmed control system on main user equipment to control and monitor oil level in reservoir, supply system pressure and setting of lubrication cycle.



DC lubricator is widely used in centralized lubrication systems for machine tools, plastics, textiles, light industry, printing, auto escalators and conveyers among other mechanical equipment.

## Technology Data

Model	P.N.	Discharge	Controller	Pressure	Viscosity	Voltage	Power	Control unit
DC-110x3	20131	108 (ml/min)	None	2.5 (MPa)	20~320 (mm <sup>2</sup> /s)	220 VAC	20 W	Meter unit
	20131D		None					PDI system
DC-110x3K	20132D		HLTC-3					Meter unit
	20134D		HLTC-2					PDI system

## HLTC-3 Series Controller

### Operation

The HLTC-3 Controller is a multi-purpose programmable controller used with industrial lubrication systems. Controller settings are saved whenever power is interrupted. Up to three operating modes can be selected which allows the controller to be used with various lubrication system designs.



### Electrical Terminal Connections

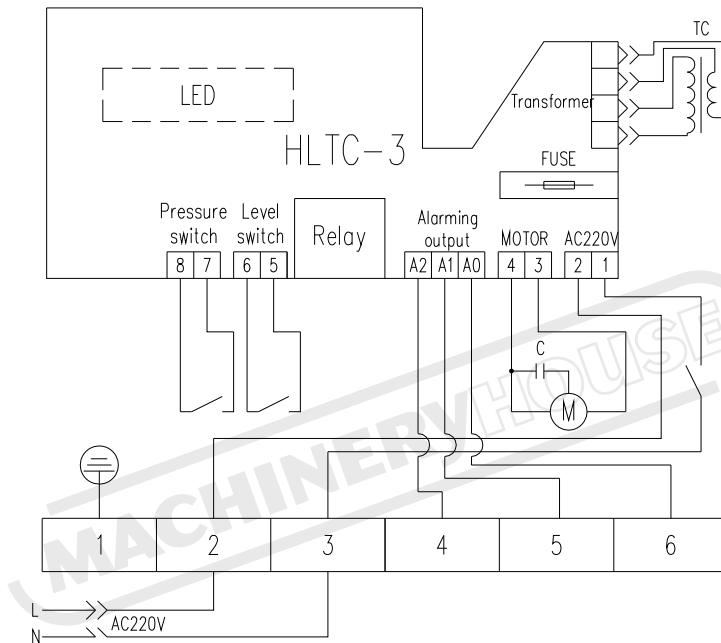

<b>Connection #</b>	<b>Description</b>
1	Positive(+) 220V AC, 2Amp
2	Negative(-)
3	Motor
4	Common
5	Level switch, closed at low level;
6	Capacity 220V,0.1Amp;
7	Pressure switch, lower 0.2MPa normal open; over
8	1.4MPa stop Capacity:220V ACm,1Amp
Relay	Capacity:22V AC,60W
Fuse	Φ5×20,1A

## Operation

### Voltage Selection

Before connecting with the power supply, set the voltage switch on the top-left of main circuit board to the correct position for desired input voltage.

### Keys Description

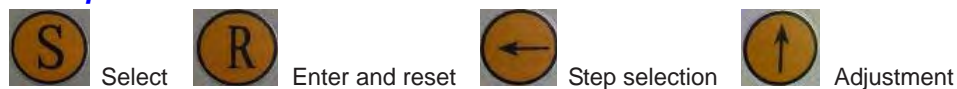

### With the controller energized

1. Press the keys and simultaneously and release to enter control mode.
2. The display panel will now show a fixed letter for the selected mode and a flashing number (0-2).
3. To select the required mode press the key.
4. Press the key to advance to the next parameter of the selected mode.
5. Repeat steps 3 and 4 above using the key to move across the digits and the key to change the value of the selected flashing digit.
6. On completion, press the key to save the data and initiate a lubrication cycle.

### Manual Override

With the controller energized press the key to initiate a lubrication cycle.

### Program Review

To review the preset data, press the key repeatedly with the controller energized.

To return to operating condition display, release key or depress key for 5 seconds.

### Fault Alarm

In any alarm condition, e.g. low level, low pressure etc., the pump will not be able to operate and the alarm lamp will illuminate. The fault condition must be rectified to cancel the alarm and reactivate the system.

### Operation Mode

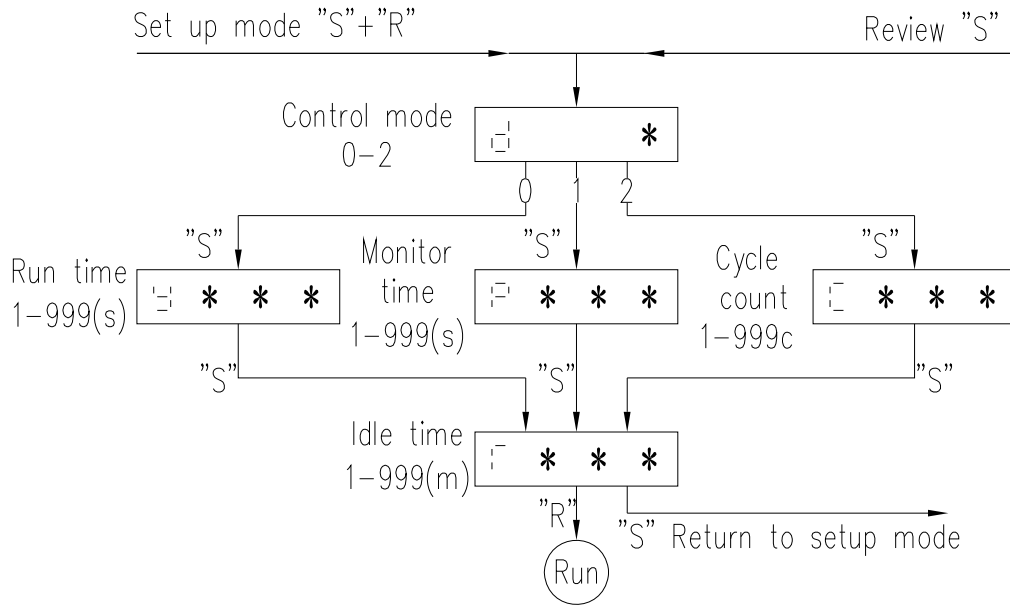

\* For lubricators fitted with low level switch

#### • Time control mode (d=0)

Recommended for Systems without a Pressure Switch

Low level alarm function enabled\*

In this mode, the lubricating system runs according to the preset run time and idle time.

#### • Pressure control mode (d=1)

Recommended for Injector Systems

Pressure switch function enabled/ Low level alarm function enabled\*

A pressure switch installed downstream from the pump functions as the key monitoring device for the entire system. Normally the system will build up sufficient pressure required to activate the pressure switch (normally open) in a predetermined period of time (called monitor time) once the pump starts. The user can adjust the monitor time to a setting greater than the time required to satisfy the pressure switch (normally 1.5 times greater). If the system fails to reach sufficient pressure during that time period an alarm signal will be displayed (yellow LED on and EEPP appears on the digital readout). Possible causes for this type of alarm could be pump malfunction, broken supply line or crushed supply line prior to pressure switch. Lubrication intervals are adjustable from 1 to 9999 minutes. A four second run delay following a pressure switch closure assures adequate pressure downstream from the pump.

#### • Cycle control mode (d=2)

Recommended for Progressive systems

Cycle switch function enabled/ Low level alarm function enabled\*

The cycle switch mounted on a progressive divider valve is the key monitoring device for the entire system. Normally when grease is being discharged from the outlets of the divider valve, a cycle pin engages with the switch, confirming a successful lubrication cycle. The controller can be programmed to allow for a predetermined number of cycle



counts (1-999). Once the preset number of counts is obtained the controller will stop the pump and revert back to the idle time setting (1-9999 minutes). If the desired number of cycle counts is not obtained within five minutes of run time (non-adjustable), an alarm signal will be displayed (yellow LED on and EEPP appears on the digital readout). Possible causes for this type of alarm could be pump malfunction, divider valve malfunction, broken supply line or blocked supply line or feed line.

## Dimensional Schematics

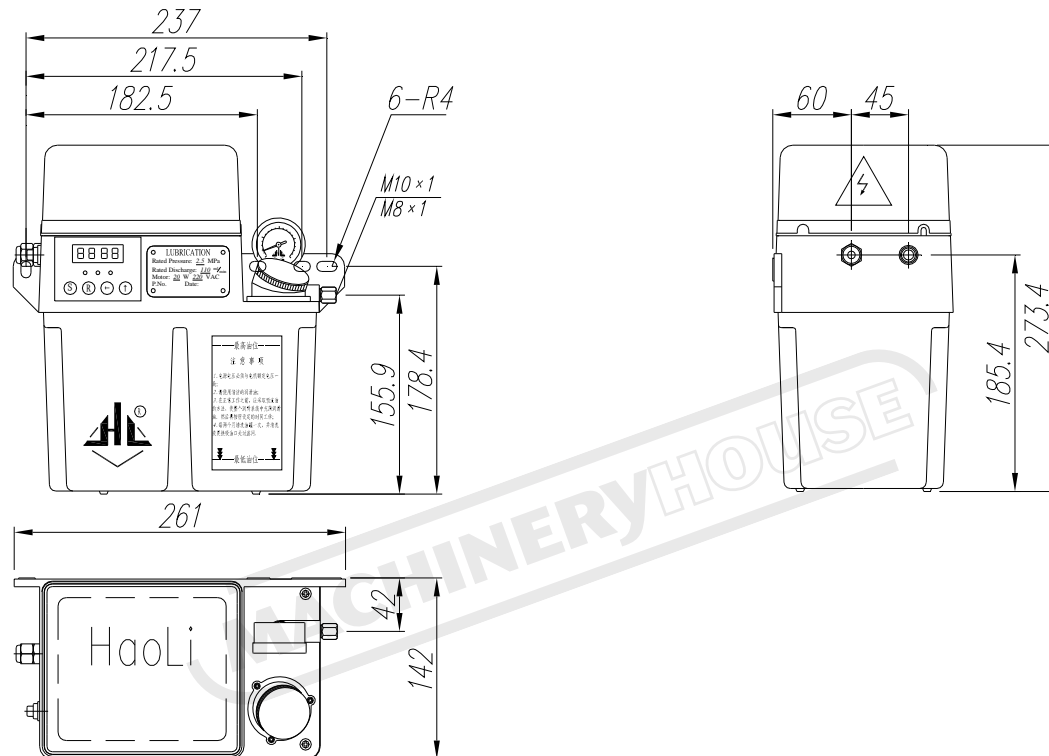



# WARNING

## General Machinery Safety Instructions

---

Machinery House  
requires you to read this entire Manual before using this machine.

- 1. Read the entire Manual before starting machinery.** Machinery may cause serious injury if not correctly used.
- 2. Always use correct hearing protection when operating machinery.** Machinery noise may cause permanent hearing damage.
- 3. Machinery must never be used when tired, or under the influence of drugs or alcohol.** When running machinery you must be alert at all times.
- 4. Wear correct Clothing.** At all times remove all loose clothing, necklaces, rings, jewelry, etc. Long hair must be contained in a hair net. Non-slip protective footwear must be worn.
- 5. Always wear correct respirators around fumes or dust when operating machinery.** Machinery fumes & dust can cause serious respiratory illness. Dust extractors must be used where applicable.
- 6. Always wear correct safety glasses.** When machining you must use the correct eye protection to prevent injuring your eyes.
- 7. Keep work clean and make sure you have good lighting.** Cluttered and dark shadows may cause accidents.
- 8. Personnel must be properly trained or well supervised when operating machinery.** Make sure you have clear and safe understanding of the machine you are operating.
- 9. Keep children and visitors away.** Make sure children and visitors are at a safe distance for you work area.
- 10. Keep your workshop childproof.** Use padlocks, Turn off master power switches and remove start switch keys.
- 11. Never leave machine unattended.** Turn power off and wait till machine has come to a complete stop before leaving the machine unattended.
- 12. Make a safe working environment.** Do not use machine in a damp, wet area, or where flammable or noxious fumes may exist.
- 13. Disconnect main power before service machine.** Make sure power switch is in the off position before re-connecting.
- 14. Use correct amperage extension cords.** Undersized extension cords overheat and lose power. Replace extension cords if they become damaged.
- 15. Keep machine well maintained.** Keep blades sharp and clean for best and safest performance. Follow instructions when lubricating and changing accessories.
- 16. Keep machine well guarded.** Make sure guards on machine are in place and are all working correctly.
- 17. Do not overreach.** Keep proper footing and balance at all times.
- 18. Secure workpiece.** Use clamps or a vice to hold the workpiece where practical. Keeping the workpiece secure will free up your hand to operate the machine and will protect hand from injury.
- 19. Check machine over before operating.** Check machine for damaged parts, loose bolts, Keys and wrenches left on machine and any other conditions that may effect the machines operation. Repair and replace damaged parts.
- 20. Use recommended accessories.** Refer to instruction manual or ask correct service officer when using accessories. The use of improper accessories may cause the risk of injury.
- 21. Do not force machinery.** Work at the speed and capacity at which the machine or accessory was designed.
- 22. Use correct lifting practice.** Always use the correct lifting methods when using machinery. Incorrect lifting methods can cause serious injury.
- 23. Lock mobile bases.** Make sure any mobile bases are locked before using machine.
- 24. Allergic reactions.** Certain metal shavings and cutting fluids may cause an allergic reaction in people and animals, especially when cutting as the fumes can be inhaled. Make sure you know what type of metal and cutting fluid you will be exposed to and how to avoid contamination.
- 25. Call for help.** If at any time you experience difficulties, stop the machine and call you nearest branch service department for help.



## Milling Machine Safety Instructions

---

Machinery House  
requires you to read this entire Manual before using this machine.

- 1. Maintenance.** Make sure the mill is turned off and disconnect from the main power supply and make sure all moving parts have come to a complete stop before any inspection, adjustment or maintenance is carried out.
- 2. Mill Condition.** Mill must be maintained for a proper working condition. Never operate a mill that has damaged or worn parts. Scheduled routine maintenance should be performed on a scheduled basis.
- 3. Leaving a Mill Unattended.** Always turn the mill off and make sure all moving parts have come to a complete stop before leaving the mill. Do not leave mill running unattended for any reason.
- 4. Avoiding Entanglement.** Remove loose clothing, belts, or jewelry items. Never wear gloves while machine is in operation. Tie up long hair and use the correct hair nets to avoid any entanglement with the mill spindle or moving parts.
- 5. Chuck key safety.** Always remove your chuck key, draw bar wrench, and any service tools immediately after use. Chuck keys left in the chuck can cause serious injury.
- 6. Understand the machines controls.** Make sure you understand the use and operation of all controls.
- 7. Tooling selection & holding.** Always use the correct cutting tool for the job you are milling. Make sure it is sharp and held firmly in place.
- 8. Cutting Tool inspection.** Inspect Drill and end mills for sharpness, chips, or cracks before use. Replace any cutting tools immediately if dull, chipped or cracked. Handle new cutting tools with care. Cutting edges are very sharp and can cause lacerations.
- 9. Reversing the spindle.** Make sure the spindle has come to a complete stop before changing the direction of the spindle. Do not slow or stop the spindle by using your hand.
- 10. Stopping the spindle.** Do not slow or stop the spindle by using your hand.
- 11. Speed selection.** Select the appropriate speed for the type of work, material, and tool bit. Allow the mill to reach full speed before beginning a cut.
- 12. Clearing chips.** Always use a brush to clear chips. Never clear chips when the mill is running.
- 13. Power outage.** In the event of a power failure during use of the mill, turn off all switches to avoid possible sudden start up once power is restored.
- 14. Clean work area.** Keep the area around the mill clean from oil, tools and chips.
- 15. Tilting head.** Use an assistant to help support the head correctly. Make sure bolts that secure the head for tilting are not loosened to much as head can slip and cause serious injury. Please refer to Mill head Tilting Instructions for correct procedure.
- 16. Call for help.** If at any time you experience difficulties, stop the machine and call your nearest branch service department for help.

# PLANT SAFETY PROGRAM

## **NEW MACHINERY HAZARD IDENTIFICATION, ASSESSMENT & CONTROL**

### Milling Machine

Developed in Co-operation Between A.W.I.S.A and Australia Chamber of Manufactures  
This program is based upon the Australian Worksafe Standard for Plant(NOHSC:1010-1994)

Item No.	Hazard Identification	Hazard Assessment	Risk Control Strategies <small>(Recommended for Purchase / Buyer / User)</small>
A	ENTANGLEMENT	HIGH	Eliminate, avoid loose clothing / Long hair etc.
B	CRUSHING	LOW	Secure & support workpiece on mill table.
B	CRUSHING	HIGH	Mill head tilting adjustment - please refer to mill head tilting instruction sheet for correct procedure.
C	CUTTING, STABBING, PUNCTURING	MEDIUM	Incorrect adjustment may result in the head becoming detached and a crushing hazard Isolate power to machine prior to any checks or maintenance being carried out. Do not adjust or clean machine until the machine has fully stopped.
D	SHEARING	MEDIUM	Make sure all guards are secured shut when machine is on. Isolate power to machine prior to any checks or maintenance.
F	STRIKING	MEDIUM	Ensure tooling is secure in chuck. Wear safety glasses. Stand clear of moving parts on machine. Remove all loose objects around moving parts. Ensure correct spindle direction when milling.
H	ELECTRICAL	MEDIUM	All electrical enclosures should only be opened with a tool that is not to be kept with the machine. Machine should be installed & checked by a Licensed Electrician.
M	HIGH TEMPERATURE	LOW	Wear appropriate protective clothing to prevent hot swarf.
O	OTHER HAZARDS, NOISE.	LOW	Wear hearing protection as required.
Plant Safety Program to be read in conjunction with manufactures instructions			



[www.machineryhouse.com.au](http://www.machineryhouse.com.au)



[www.machineryhouse.co.nz](http://www.machineryhouse.co.nz)

Authorised and signed by:  
Safety officer:

Manager:

  
.....  
  
.....

Revised Date: Aug-08